



U.S. NAVY NUCLEAR-POWERED AIRCRAFT CARRIER ENTERPRISE

Overall Length	341.3m
Flight Deck Width (maximum)	78.3m
Waterline Length	317m
Beam	40.5m
Draught	10.8m
Displacement (standard)	75,700t
Displacement (loaded)	89,600t

SPECIFICATIONS

Nuclear Reactors	Pressurized Water Cooled A2W x 6
Main Engines	Geared Steam Turbines x 4
Power	280,000shp
Speed	36knots
Armament	20mm Vulcan/Phalanx CIWS x 3 Ses Sparrow AA Missile Launcher Mk29 x 3
Steam Catapults	4

Side Elevators	4
Aircraft	80 - 95
Complement	5,500

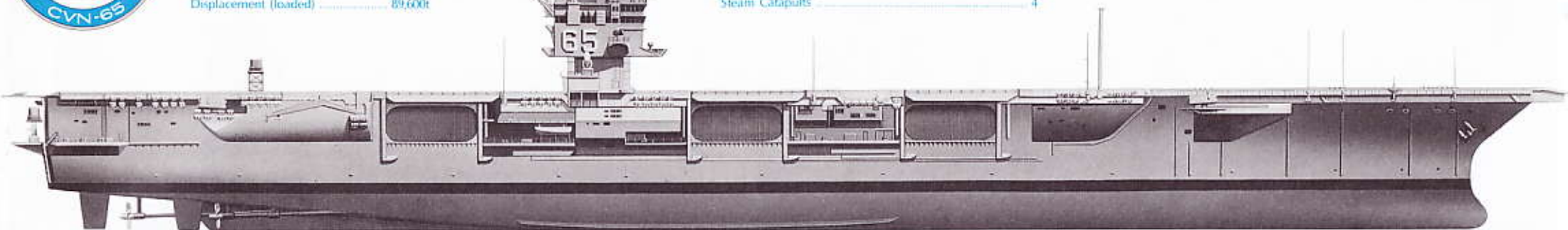

1:350 AIRCRAFT CARRIER U.S. ENTERPRISE CVN-65

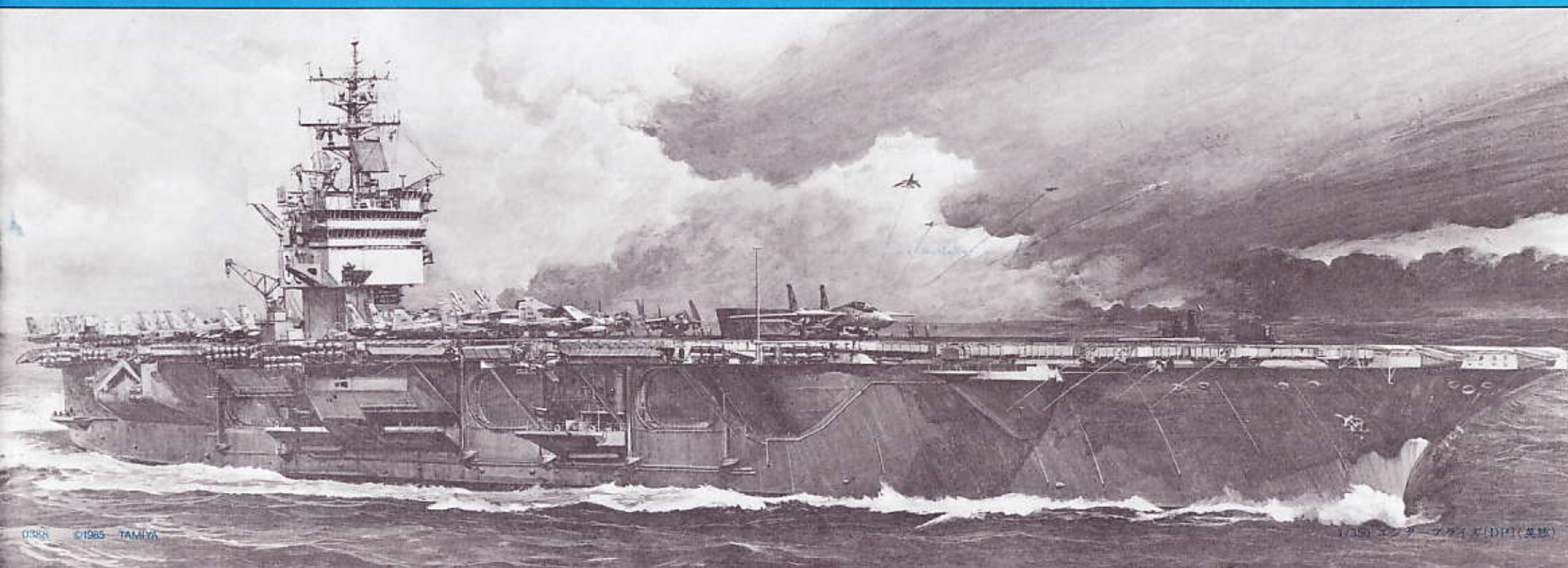

U.S. AIRCRAFT CARRIER CVN-65 ENTERPRISE

The United States Navy Aircraft Carrier CVN-65 Enterprise, also known as the "Big E", is the worlds largest ship and the first nuclear powered aircraft carrier. Webster defines the word Enterprise as meaning "Undertaking, Project, A business organization, Initiative, etc.," and the CVN-65 fits all of these definitions perfectly. The carrier Enterprise is the 8th U.S. Naval vessel to carry the name, and the first one was launched in 1755 as a one masted sailing ship that served during the American Revolution and its displacement was only about 1/1000 of the current namesake. Following the end of the second conflict, the U.S. Navy had on hand 99 aircraft carriers, with another 39 under construction, but with the completion of hostilities construction was halted and many of the others were mothballed. In 1947, only 20 carriers were in active service, including the Midway. With the advent of jet aircraft and heavier gross weights of the new planes, a large 60,000 ton class of carrier was discussed to cover these needs. Construction was begun on CVB-58 in 1949, a 65,000 ton class carrier, but was halted after only five days, because of a change in political thinking, wherein emphasis was placed

upon tactical long range bombers instead. With lessons learned during the Korean conflict, 4 new carriers, of the Forrestal class, at 60,000 tons were constructed during the 1955—59 time period, and the improved Constellation was completed in 1961. During this period, the U.S. Navy had progressed in the development and testing of a trial nuclear powerplant, suitable for surface ships, and was first used in the Cruiser Long Beach, making it the first nuclear powered surface vessel. Funding was received by the Navy for the construction of a 75,000 ton displacement nuclear powered carrier and the Newport News Shipbuilding and Dry Dock firm began construction on 4 February 1958. The CVN-65 was launched as the Enterprise on 24 September 1960 as the largest ship afloat. Its waterline is 317 meters long and has a beam of 40.5m, but even with these awesome dimensions it has the same draught as that of the Kitty Hawk class carriers. The Enterprise is powered by eight pressurised-water cooled A2W nuclear reactors and 4 geared steam turbines by Westinghouse, which produces 280,000 horsepower. With this power the Enterprise can travel 140,000 n.m. at 36 knots or

400,000 n.m. at 20 knots. Cost of construction was 450 million dollars.

In January 1979 the Enterprise completed her 3rd refueling and overhaul, with many modifications updating the state of the art in electronics, communications and weapons. The CVN-65 carries 94 aircraft which include F-14A Tomcat, A-7E Corsair II, A-6E Intruder, KA-6D Intruder, S-3A Viking, EA-6B Prowler, E-2C Hawk Eye and SH-3H Sea King helicopters.

* * *

Der amerikanische Flugzeugträger CVN-65, besser bekannt als "Enterprise", ist das grösste Schiff der Welt und das erste Trägerschiff mit Atomtrieb. Die "Enterprise" ist das achte U.S. Navy-Schiff mit diesem Namen. Das erste Einmast-Segelschiff mit diesem Namen wurde 1755 im amerikanischen Krieg vom Stapel gelassen, hatte aber nur ungefähr 1/1000 Verdrängung der jetzigen CVN-65. 1945 hatte Amerika ca. 99 Trägerschiffe im Einsatz und weitere 39 im Bau. Nach Beendigung der damaligen Konflikte wurden neue Bauvorhaben gestoppt und viele Flugzeugträger eingemottet.

1947 standen nur noch 20 Träger einschliesslich der "Midway" im Dienst. Durch den vermehrten Einsatz von Flugzeugen mit Düsenantrieb und dadurch auch mit grösseren Gewichten stellte man fest, dass der Bedarf eines Flugzeugträgers der 60.000 ton Klasse dringend notwendig ist. 1949 begannen die Arbeiten an der CVB-58, einem Trägerschiff mit 65.000 ton, wurden aber bereits nach 5 Tagen gestoppt, infolge Umdenkens der Politiker, wonach taktische Bomber mit übergrosser Reichweite wesentlich besser eingesetzt werden konnten. Nach den Erfahrungen im Korea-Konflikt wurden vier neue Trägerschiffe der Forrestal-Klasse in den Jahren 1955—1959 gebaut. Eine verbesserte "Constellation" wurde 1961 fertiggestellt. In diesen Jahren konnte die U.S. Navy die Entwicklung und Erprobung des Kreuzers "Long Beach", dem ersten Schiff mit Atomtrieb, erfolgreich beenden.

Photo: "Ship of the World"



Die Navy bekam die Mittel für den Bau eines Flugzeugträgers mit einer Verdrängung von 75.000 ton und Atomtrieb. Die Firma New Shipbuilding and Dry Dock in Newport begann am 4. Februar 1958 mit dem Bau der CVN-65 mit Namen "Enterprise", der Stapellauf erfolgte am 24. September 1960, es war das grösste Schiff der Welt. Die Waterline hat eine Länge von 317 Metern, die Breite beträgt 40,5 Meter.

Angetrieben wird die "Enterprise" von acht wassergekühlten Reaktoren A2W und vier Dampfturbinen von Westinghouse, die zusammen 280.000 PS erzeugen. Mit dieser Kraft kann das Schiff 140.000 N.M. mit 36 Knoten oder 400.000 N.M. mit 20 Knoten fahren. Die Gesamtkosten liegen bei 450 Millionen Dollar. Im Januar 1979 wurde die "Enterprise" das dritte Mal "aufgetankt" und überholt, viele Verbesserungen erfolgten, um die Elektronik und Bewaffnung auf den neuesten Stand zu bringen.

Der Träger CVN-65 hat 94 Flugzeuge an Bord wie F-14A Tomcat, A-7E Corsair II, A-6E Intruder, KA-6D Intruder, S-3A Viking, EA-6B Prowler, E-2C Hawk Eye und SH-3H Seaking Helicopter.

Photo: "Ship of the World"

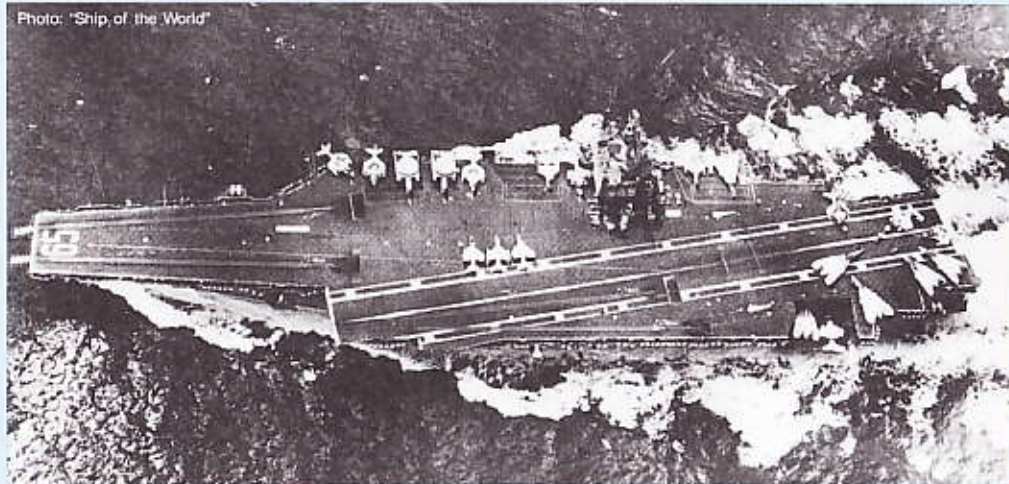

<Identification Chart>

- ① Mk.29 Sea Sparrow Launcher
- ② No.4 Side Elevator
- ③ Mk.7 Barricade Stanchion
- ④ Mk.7 Arresting Gear
- ⑤ No.4 Mk.6 Jet Blast Deflector
- ⑥ No.3 Mk.7 Jet Blast Deflector
- ⑦ No.4 Steam Catapult
- ⑧ Fresnel Lens Optical Landing System

- ⑨ SPS-49 Long Range Antiaircraft Search Radar
- ⑩ Mast
- ⑪ QE-82 Satellite Communication Antenna
- ⑫ Ghost Ship Maker Antenna (ECM)
- ⑬ No.3 Steam Catapult
- ⑭ Angled Deck Center Line
- ⑮ Landing Area Runway Marking
- ⑯ Angled Deck

- ⑰ No.2 Mk.7 Jet Blast Deflector
- ⑱ No.1 Mk.7 Jet Blast Deflector
- ⑲ Free Deck Launch Line
- ⑳ Ammunition Elevator
- ㉑ Communication Antenna

- ㉒ No.2 Steam Catapult
- ㉓ Flight Deck Crew Sheltering Line
- ㉔ No.1 Steam Catapult

Explanation by Takahiko Sena
Illustration by Tsunehide Mori

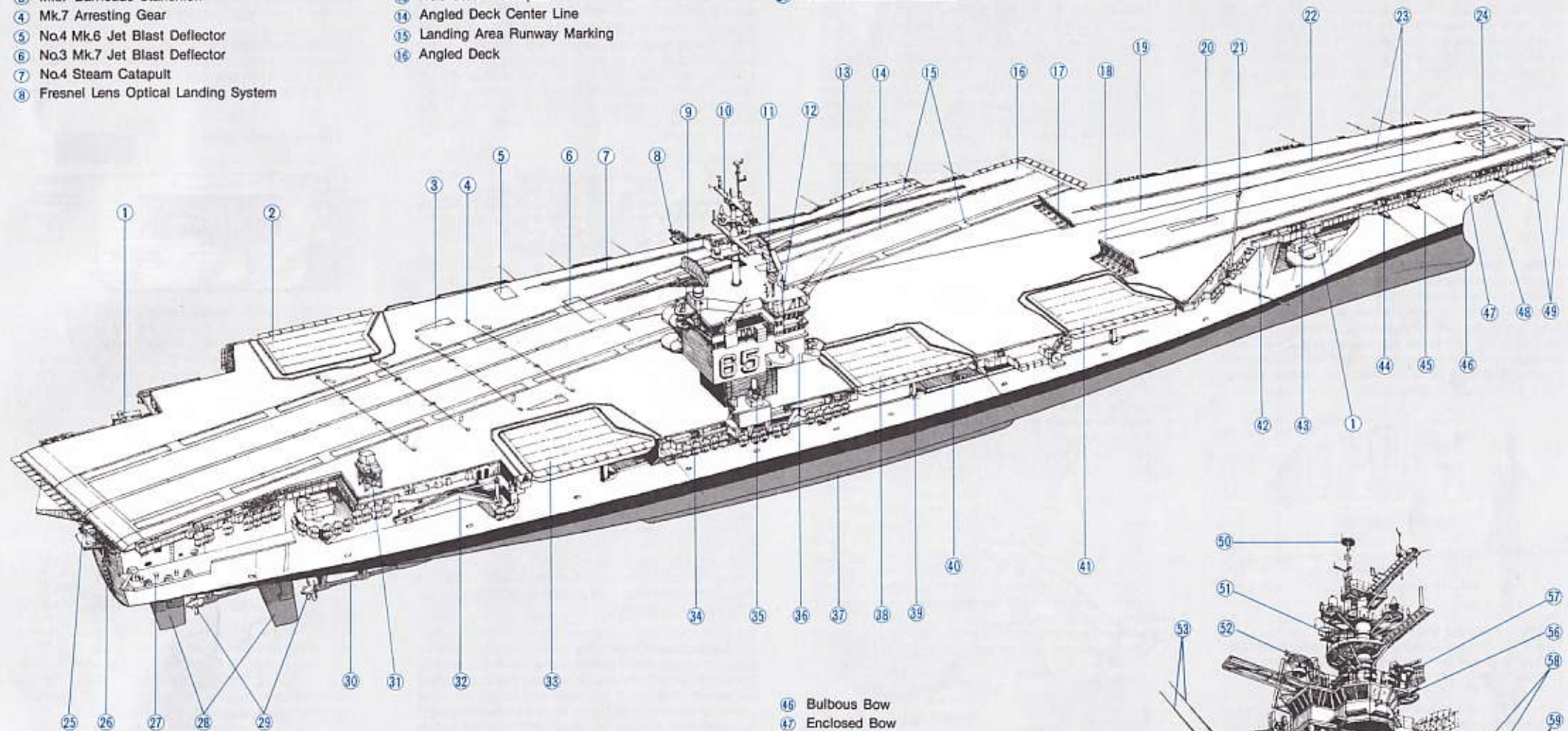

- ⑵ Engine Test Stand
- ⑶ Landing Signal Lights
- ⑷ Starboard Rear Sponson
- ⑸ Rudders
- ⑹ Propellers
- ⑺ Propeller Shaft
- ⑻ SPN-35 Full Automatic Landing Guide System
- ⑽ Large Crane for Aircraft
- ⑾ No.3 Side Elevator
- ⑿ CO₂ Life Raft Containers

- ⑽ CIWS Vulcan/Phalanx
- ⑾ Island/Bridge
- ⑿ Bilge Keel
- ⑿ No.2 Side Elevator
- ⑿ Elevator Guide Rail
- ⑿ Elevator Sponson
- ⑿ No.1 Side Elevator
- ⑿ Catwalk
- ⑿ Hose Reel
- ⑿ Whip Antenna Support
- ⑿ Whip Antenna

- ⑿ Bulbous Bow
- ⑿ Enclosed Bow
- ⑿ Anchor (30ton)
- ⑿ Bridle Retrievers
- ⑿ TACAN
- ⑿ SPS-10 Surface Search Radar
- ⑿ SPS-48 Three-dimensional Antiaircraft Search Radar
- ⑿ UHF Whip Antenna
- ⑿ Navigation Bridge
- ⑿ Combat Bridge
- ⑿ Flight Control Center
- ⑿ SPS-58 Low Altitude Warning Radar
- ⑿ UHF Antenna for Aircraft
- ⑿ SPS-65 Low Altitude Warning Radar

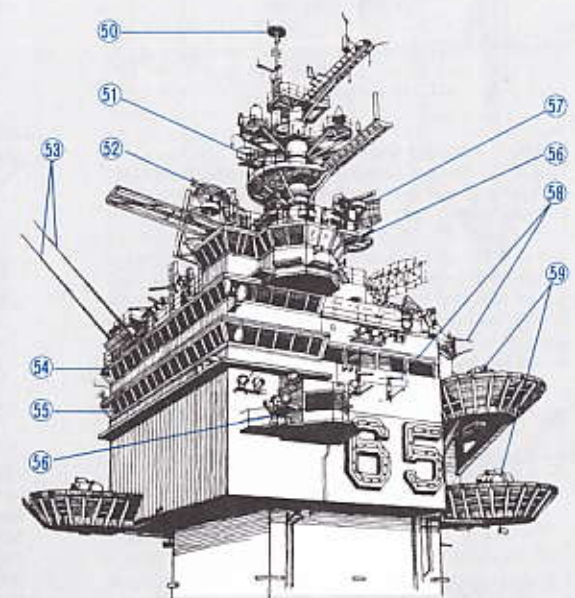

① Sea Sparrow Launcher

The Sea Sparrow is a ship mounted missile system modified from the air to air AIM-7E Sparrow III used by the U.S. Navy. It was developed during the 1970's to cope with the anti-ship missiles being employed by other countries. The missile is 3.65m in length, 20cm in diameter and has a 1m wingspan. Warhead is 30kg of high explosives and employs a proximity fusing system. It is propelled by a solid fuel rocket and is controlled by a semiactive homing radar. It has a maximum range of approximately 25km and is extremely accurate and effective.

Sea Sparrow Launcher



③ Mk. 7 Barricade Stanchion

The Mk. 7 barricade and stanchion is an aircraft arresting system employed on the recovery flight deck of the Enterprise to halt disabled aircraft and prevent them from damaging other aircraft, facilities or personnel. The barrier is a heavy duty net of nylon mesh, supported by two fast acting stanchions that raise the net across the landing deck. It will stop the aircraft with little or no damage to the airframe or flight personnel.

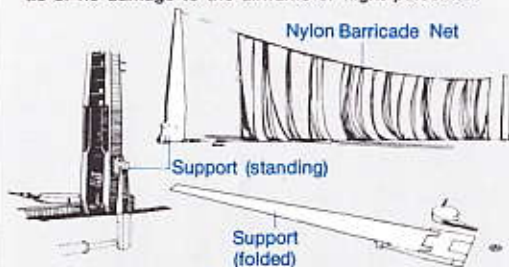

④ Mk. 7 Arresting Gear

This is the carriers primary system for recovery of landing aircraft. Consisting of 4 steel cables, associated pulleys, hydraulic piston, compressed air tanks etc, the landing aircraft's tail hook engages one of the cables and it is brought to a quick, but smooth halt. The aircraft's kinetic energy is absorbed by the cable pulling on the attached hydraulic piston against a combination of fluid and compressed air, bringing the aircraft to a rapid stop. A 30 ton aircraft landing at a speed of 140 knots, will be stopped in a length of about 91.5 meters.

Mk.7 Arresting Gear

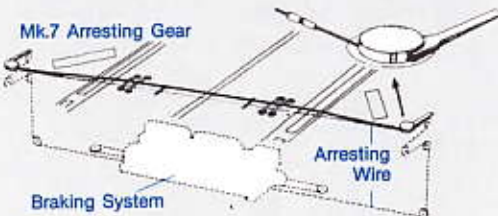

⑤ Mk. 7 Jet Blast Deflector

When jet aircraft first began to be used on aircraft carriers, the problem of their jet exhaust heat and blast effects caused considerable problems in the launching of the aircraft. The solution was to employ a blast deflector to turn the exhaust upwards or to the side. On the Enterprise the Mk. 7 J.B.D. is used on the No1, 2 and 3 catapults and a Mk. 6 on the No4. All four deflectors retract into the flight deck, flush with the surface and are activated by hydraulic cylinders, raised to about a 70 degree angle to the flight deck. Water cooling pipes are buried in the deflector to protect the barrier from heat damage from the hot aircraft exhaust when at the take off setting. The cooling water starts flowing as soon as the barrier is placed in the raised position.

Mk.7 Jet Blast Deflector

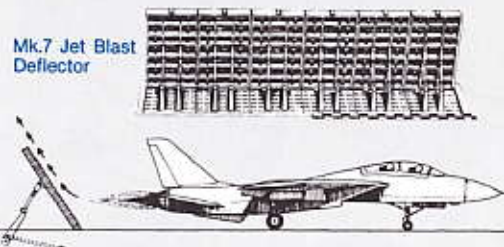

⑦ Steam Catapult

The catapult method of launching conventional jet aircraft from carriers, is used by most countries of the world. The Enterprise uses a steam unit type C-13, Mod Q, which has a stroke length of 76.2 meters. It can launch a 35.4 ton aircraft at 140 knots at a rate of one per minute. Four of these catapults are employed on the Enterprise, two at the bow and two on the angled deck.

Steam Catapult

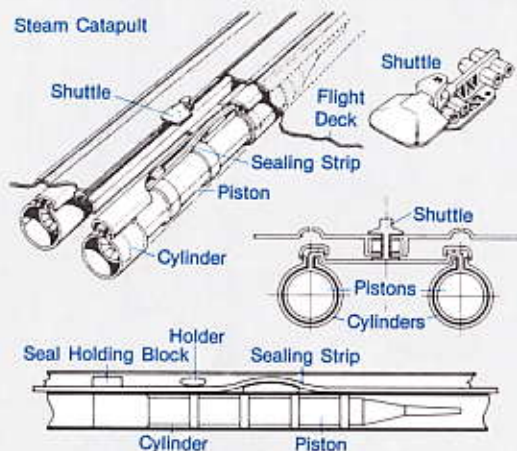

⑩ Fresnel Lens Optical Landing System

When the landing speeds of the newer jet aircraft made the mirror landing system less effective, the British Royal Navy and the General Electric Company of the U.S.A. developed a new Fresnel Lens system which was soon put into use by the U.S. Navy. The system uses 5 fresnel lens (developed by the French Opticist Fresnel) set vertically with a lamp stand as a light source behind them.

On both sides of the vertical lens, ten horizontal lens are projected, which include 7 red lights. This landing system is positioned on the port side of the center deck. The landing area is 762m from the lens and at an azimuth angle of 40 degrees. When the aircraft is in the proper approach position, all of the lenses have the same brightness. If the aircraft is above the glide path, the upper lenses are weaker and if left of the glide path the left side lenses are weaker. Thus, the pilot of the approaching aircraft understands his aircraft's position and can make flight adjustments accordingly. As different aircraft have different approach speeds and glide slope angles, minute adjustments of the angle of the lenses can be made from the flight control center by remote control.

Fresnel Lens Optical Landing System

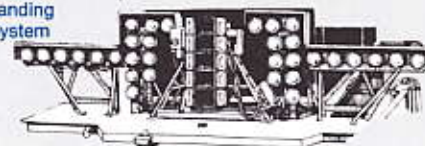

⑫ Ghost Ship Maker Antenna

Navel warfare in this day and age, depends a great deal upon modern electronic systems, for passive and active offense and defence. If a ship wants to attack an enemy with missiles, she must first find the vessel by using her own radar, the radar information from another friendly ship or aircraft that have a data link connected with her. When the defending side detects that a radar signal is locked on her, she can judge the enemy's movements and prepare herself for the coming attack. This is known as ESM or Electronic Support Measures. Electronic Counter Measures ECM consist of jamming the enemy's radar or disturbing its transmission by transmitting a false signal which would give a wrong indication on the screen. A more advanced system of Electronic Countermeasures is to "Trick" the enemy ship into attacking a ghost ship. The friendly ship sends out phantom signals from her own radar and it is received by the enemy and plotted in an entirely different location. When the attack begins, the enemy's missiles attack the ghost ship, rendering the real ship safe from damage.

⑭ Angled Deck Center Line

A highly visible center line is marked from the front of the angled deck to the rear, to assist the pilot in landing his aircraft. The line is 36" wide and is painted either yellow or red and white, every 45 feet. The pilot is able to concentrate more on his glide path using the fresnel lenses, as he can automatically correct by reflex action his approach direction.

⑮ Landing Area Runway Markings

These are symmetric grill pattern white lines painted to the left and right of the center line to define the landing and taxi areas of the recovery deck. They also provide the pilot with a better depth of field for landing operations.

⑯ Angled Deck

The Angled deck, so conspicuous among modern aircraft carriers, is angled away from the bow so that recovery of aircraft, and simultaneous take offs from the bow can be achieved without any interference. It allows continued simulated flight approaches to landing and go around

for training purposes that has an overall effect of maintaining pilot efficiency and reduction of accidents.

⑰ Free Deck Launch Line

This is a 6 inch white line, drawn from the center flight deck to the front catapult. It is used as a take off center line for those aircraft not using the catapult.

⑲ Landing Signal Lights

These are 12 vertically placed lights on the starboard side of the stern of the ship, and are used as approach lights for night operations, and also as stern indicator lights.

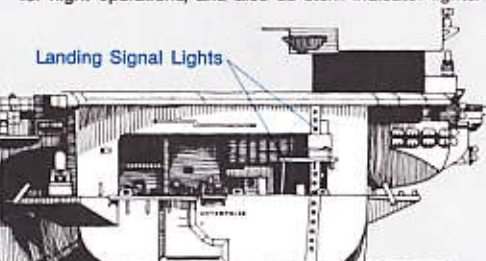

⑳ SPN-35 Full Automatic Landing Guide System

Landing on an aircraft carrier is not the easiest thing in the world to do, and many different systems have been employed to make it easier for the pilot to accomplish this task. Mirror-landing systems, Fresnel Lens Optical Systems etc. have been and are being used, but they are optical guide systems and have limitations during extremes of weather and darkness. A more sophisticated system called the CCA (Carrier Controlled Approach) is now being used more frequently. The CCA communicates the approach data directly to the aircraft's auto-pilot, making the necessary flight corrections automatically to touch down, making bad weather landings safer.

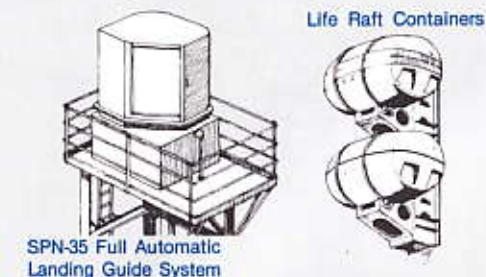

SPN-35 Full Automatic Landing Guide System

㉑ Life Raft Containers

Rubber boats for lifesaving purposes are mounted around the ship for emergencies. They are automatically inflated when released from their cocoon like containers. When required, the life rafts are dropped from the side of the ship, inflated with CO₂ and each is large enough to carry 20 persons. Emergency rations, water and medical provisions plus a tent like covering for protection from the weather is carried aboard.

㉒ CIWS Vulcan/Phalanx

The Close In Weapon System (CIWS) is composed of the Vulcan 20mm rapid firing cannon and the sophisticated Phalanx fire control system. The Vulcan is a six barreled revolving cannon with a rate of fire exceeding 3000 rounds

per minute. It has an effective range of 1,500 meters with a muzzle velocity of 1,120m a second. The CIWS Vulcan/Phalanx system consists of a gun mount housing the gun and a dome shaped radar cover painted white. Both search and trailing radars are housed in the dome, along with the firing control system computers. They are effective in this purpose from a distance of 1,500 meters. With its tremendous fire power and accurate computer/radar guidance system, the CIWS Vulcan/Phalanx protects the ship from any guided missiles that may have passed through the point defense system guarding the Enterprises outer defenses.

CIWS Vulcan/Phalanx



36 Island/Bridge

The distinctive island of the Enterprise is located on the starboard side of the ship a little after of center. When first completed, her island had a very unique shaped structure consisting of a dome shaped top resting upon a box type bridgework assembly. When the third retrofit was done to the Enterprise in 1978-82, this island appearance was completely altered and now looks much like the island of Kitty Hawk class carriers. Being powered by nuclear reactors, there is no funnel nor associated smoke, that is present on oil fired carriers, making for easier recovery of aircraft due to better visibility during approach. Elimination of the large funnel has made the island more compact and better suited for complexities of modern combat air operations. When first completed the Enterprise utilized SPS-32 and 33 radars, plus many ECM antennas, which were located on all four sides and top dome of the ship. These were all removed during retrofit. The island consists of 8 floors, with the navigation bridge located on the 7th floor. The combat bridge is located on the 6th, with the flight control center projecting out the port side. Four large fan shaped projections extend out from the sides of the island and are mounts for the SPS-65 low altitude radar warning system. The modified top floor serves as a shelter for the watchmen who are always present while at sea. The many and varied radars are located around the island and on the large supporting mast. The SPS-48 three dimensional radar and SPS-49 anti-aircraft search radar systems were added during the 1978-82 modification program. It is said that only the U.S.S. Enterprise has an elevator for transporting VIP's from the flight deck up to the bridge.

38 Side Deck Elevators

In former times, aircraft carrier deck elevators were located in the center of the launch and recovery areas of the deck and if damaged during conflict, rendered the entire ship out of service. In 1941, the Essex class carriers began using the side deck elevators, which were found to be excellent. From that time on, all U.S. carriers employed side deck elevators. The elevators are 23.5 meters in length, and 15.9 in width, with a total area of

374 sq. meters. That's a large elevator and even though made up of aluminum alloy, weighs 105 tons. It can move a 50 ton aircraft from hangar to flight deck in 30 seconds, and each elevator can move one aircraft per minute.

40 Elevator Sponson

The elevator sponsons are projections on the sides of aircraft carriers, attached at the same level as the hangar deck. They are used for mounting weapon systems, fire control systems, search lights, etc. They are also used when replenishing supplies at sea, and tying up at quays, as they also have the necessary davits, chocks and capstans.

42 Catwalk

This is a walking area surrounding the flight deck and is one step below the level of the flight deck. It is used as a shelter for launch and recovery crews during operations.

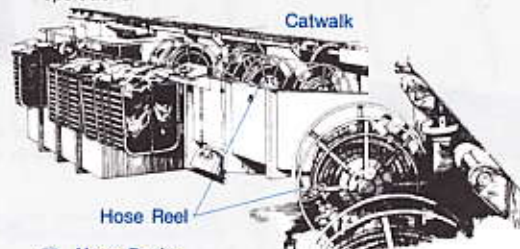

43 Hose Reels

Fire hose reels are located around the entire flight deck and are concentrated in the areas of aircraft recovery. Located on or near the catwalk, they are always near at hand for emergency purposes. Similar in appearance to those seen on city fire trucks, they can also be attached up to a nuclear, biological and chemical (NBC) sprinkler systems for clearing the flight deck of NBC contamination during combat, quickly and efficiently. This system of hose reels and sprinkler system can cope with any fires that may erupt on the flight deck.

45 Bulbous Bow

The underwater front bow swells to a large bulbous shape at the front to reduce the resistance of the water on the ship during sailing. This shape is now used on the majority of large ships being constructed for naval and commercial operations.

47 Enclosed Bow

Also known as the hurricane bow, this development came about when considerable damage occurred, during rough weather, to the flight decks of earlier carriers where the area between the flight deck and hull was open. By closing off this area and extending the deck slightly, a more streamlined bow shape, plus a great strengthening of the forward deck, allowed much better penetration with no damage during rough seas.

49 Bridle Retriever

On those aircraft that do not utilize a nose gear catapult launch system, a bridle of steel cable is employed. Both ends of this cable have rings which attach to the aircraft, with the center of the cable attached to a shuttle on the catapult. The shuttle attaches to the piston of the catapult and when triggered, propels the shuttle,

bridle and aircraft to launch speed. Upon reaching the end of the catapult, the bridle falls away from the aircraft, and in former times, fell into the sea and was lost. Being that this was not economical, a system of retrieving the bridle for reuse was developed. The bridle retrievers are the two horn like projections at the front of the launch deck. After the aircraft being launched has released the bridle, the retriever automatically recovers it, wherein the crew can transport them back to the attachment area for use in subsequent launches. The F-14 Tomcat aircraft does not require the use of a bridle during launch, as it has a built in catapult launch attachment on its nose gear. Protective personnel safety nets surround the projecting bridle retrievers and forward edge of the launch deck.

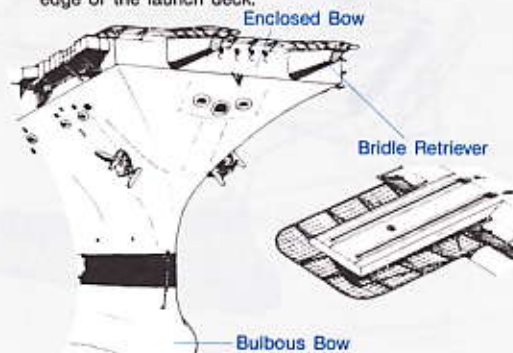

52 SPS-48 Three Dimensional Radar

The SPS-48 radar measures and analyzes the three dimensional information of height, distance and direction of an object, and projects this on the scope. The merits of this type of system is the use of high speed scanners, rotating around a vertical axis with the radar at its center. Height and distance are measured with a very narrow beam and it is said that this system can search and track an area of sky up to an altitude of 35,000 meters and at a distance of over 400km. This type of radar system is now employed by the great majority of naval vessels mounting antiship missiles of the Terrier, Tartar, etc. types. It is one of the main defense radar systems employed by the U.S.S. Enterprise; however, it can also be utilized in search and rescue missions when necessary.

SPS-65 Low Altitude Warning Radar



59 SPS-65 Low Altitude Warning Radar

The SPS-65 radar system was developed by the Westinghouse company after modifying the SPS-58 anti-aircraft search radar. This sophisticated system came into being to counter the threat of the new low altitude cruise type anti-ship missiles being employed by many nations. Said to utilize the "D" band frequency range and an automatic search and tracking function, details of

the SPS-65 are still highly classified, so its true capabilities are unknown. During the modifications of the Enterprise, these new radar installations were placed on the four sponsons located on the island. They are utilized for airspace surveillance and work in concert with the Sea Sparrow missile system and Vulcan/Phalanx CIWS.

54 Navigation Bridge

Located on the 7th floor of the island, the ship's captain and his staff use this area for conning the ship. Navigation and communication systems needed for the maneuvering of the ship are located in this area. The chart and maneuvering rooms are also located on this floor. On all capital warships, the navigation bridge is located at a high point above the waterline for a better view of the entire ship, and its surrounding area. The Captain and approximately 10 officers and men are stationed here.

55 Combat Bridge

The combat bridge is located directly under the navigation bridge, and it is here, during the time of combat, that the commander directs operations. When the Enterprise acts as a flag ship, the commander and his staff direct the fleet's movement from this area.



Aircraft Tie-down Pads

When aircraft are parked on the hangar and flight decks, they are affixed to the decking by chains, to prevent them from moving during rough seas. The chains have hooks at both ends and one end is fastened to a ring on the aircraft and the other end to the deck pad eye. Rings on the rear of the aircraft, wings and undercarriage are used to secure it to the deck, and the chain can withstand a load of 4.5 tons. The pad eyes on the deck are spaced at an interval of 1.8 meters fore and aft and 2.3 meters port and starboard.

Deck Surveillance Television

TV cameras are arranged to monitor the flight deck operations, launching and recovery of aircraft. These cameras are mounted on the island and the pictures are monitored in the bridge. This provides immediate response to any emergency.

Tow Tractors

For movement of aircraft around the flight deck, highly mobile MD-3 tow tractors or SD-1C parking dollies are used. Employing the universal NT-4 tow bar, the pins are inserted into the mounting holes of the aircraft nose gear and then the bar is attached to the tractor or parking dolly, for towing.

Mobile Crane

A mobile, heavy duty crane is required for removal of crashed or disabled aircraft from flight deck as soon as possible. The NS-50 crane provides this capability.

**READ BEFORE
ASSEMBLY.**
**ERST LESEN
— DANN BAUEN.**



★ Study the instructions and photographs before assembly.
★ You will need a sharp knife, a screwdriver, a file and a pair of pliers.
★ Use cement sparingly. Use only enough to make a good bond.
★ Apply cement to blue printed areas prior to joining.

● This mark denotes paint color, with color names and numbers for Tamiya Acrylic Paints and Tamiya Paint Markers. Page 24 has detailed painting instructions; however, some parts should be painted prior to model's completion, and these are called out during assembly.

★ Vor Beginn die Bauanleitung studieren und den Nummern nach die Elemente zusammenbauen.

★ Bauteile nicht vom Spritzling abbrechen, vorsichtig abschneiden oder abwickeln.

★ Teile vor Kleben zusammenhalten, auf genauen Sitz achten. Nicht zuviel Klebstoff verwenden. Kleine Teile hält man mit Pinzette fest.

★ Vor Zusammenfügen auf die blauen Flächen Klebstoff auftragen.

● Dieses Zeichen zeigt die Farbe und Farbnummer der Tamiya Acryl-Farben und Paint Marker

«Cutting off Parts»

«Abschneiden einzelner Teile»

Do not break parts away from sprue, but remove them carefully with a cutting tool. Bauteile nicht vom Spritzling abbrechen, vorsichtig abschneiden oder abwickeln.

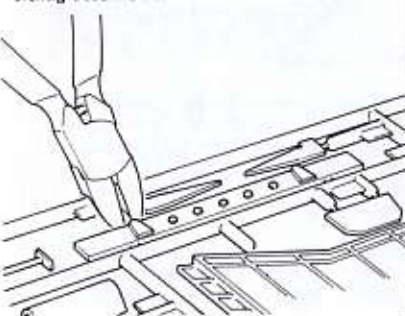

1 Attaching Bow Bug Einbau

If there is no indication of paint color, paint in hull color.
Wo keine Farb angebe, in der Rumpffarbe bemalen.
Hull Color Light Grey (XF-66): 3 + Flat White (XF-2): 1
Farbe des Rumpfes (XF-66) 3 Teile, Flat White (XF-2) 1 Teil
Bottom Color Flat Red (XF-7): 2 + Flat Brown (XF-10): 1
Farbe des Kieles: Flat Red (XF-7) 2 Teile, Flat Brown (XF-10) 1 Teil

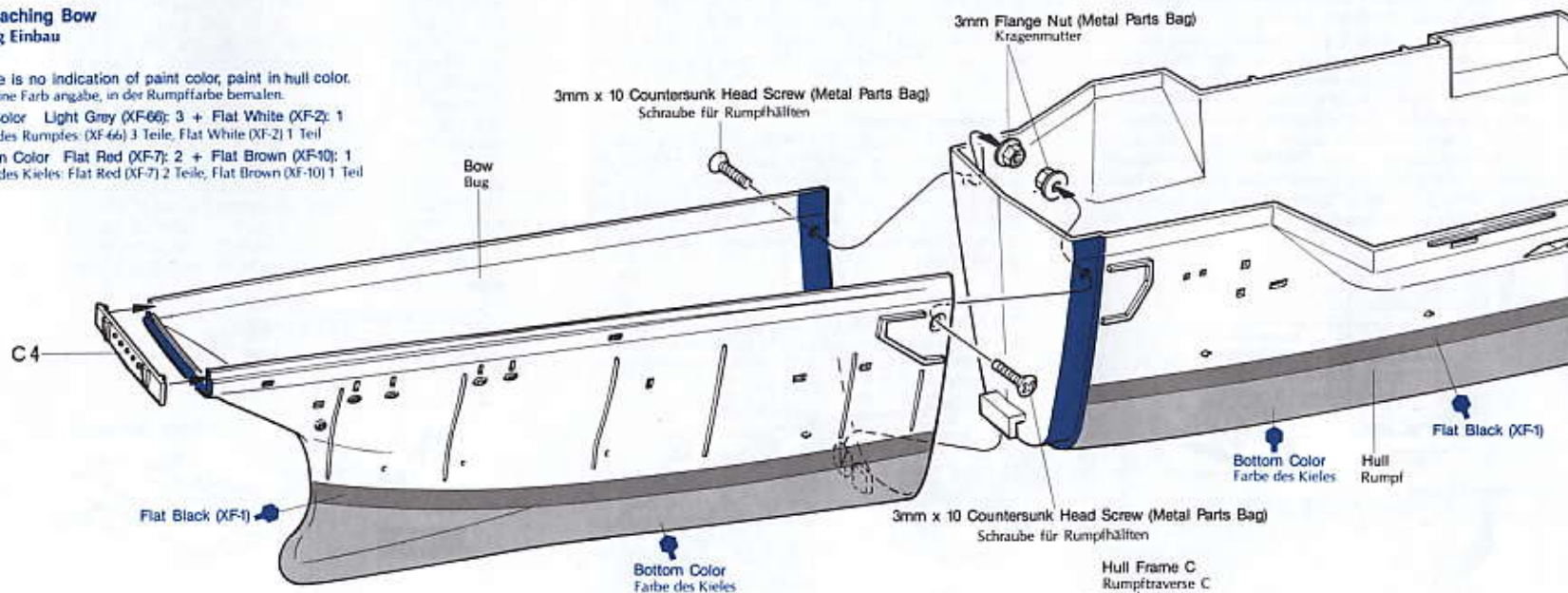

2 Attaching Elevator Guide Rails Aufzug-Führungsschienen

★ Select B9, 11, 13 or B8, 10, 12. If you attach side elevators at down position at step ① and ②, use B8, 10 and 12.
★ Wenn die Seitenaufzüge gesenkt eingebaut werden, siehe Step ① und ②. B8, B10 und B12 einbauen.

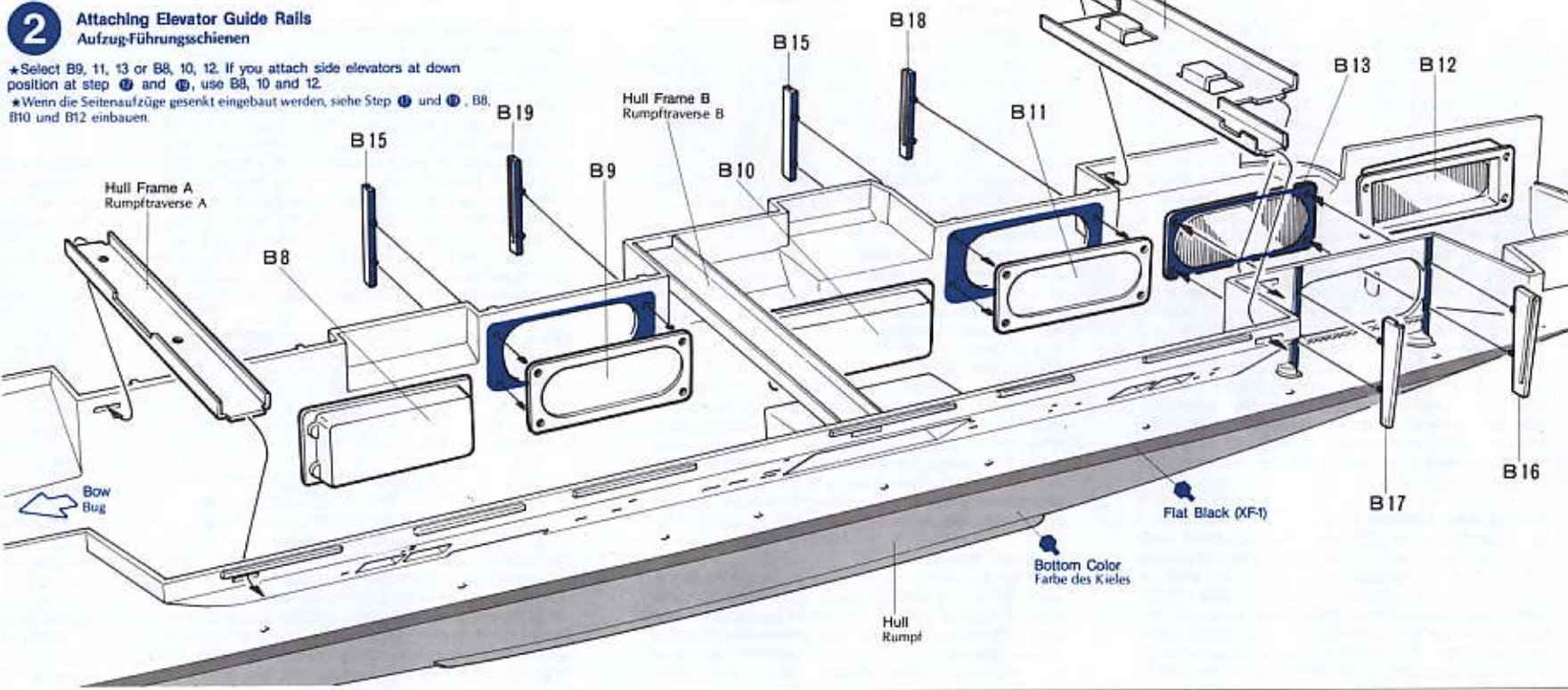

3 «Mk.29 Sea Sparrow Launcher»
 «Mk. 29 Sea Sparrow Raketenwerfer»
 *Make 3 sets. (Use 2 sets in step ④.)
 *3 Satz machen. (Für Step ④ werden 2 Satz benötigt.)

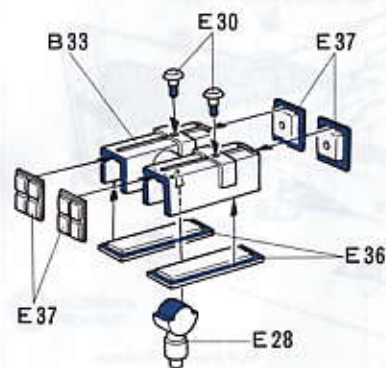

«Attaching E28»
 «E28 Einbau»

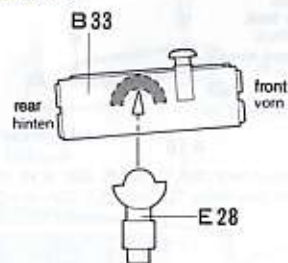

«Attaching Anchor (B14)»
 «Anker (B14)»

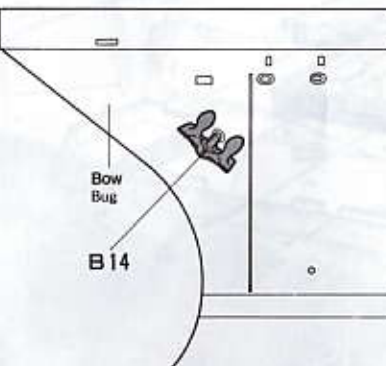

TAMIYA ACRYLIC PAINTS
 Need precise color matching?
 Try the new Tamiya acrylic
 paints. Engineered by modelers
 for modelers' use. The final cover for the
 finest models. Insist on Tamiya for
 perfect results.



3 Bow Parts
 Rumpfanbauen

«Bow Vulcan/Phalanx Sponson»
 «Vulcan/Phalanx Raketen-Basis»

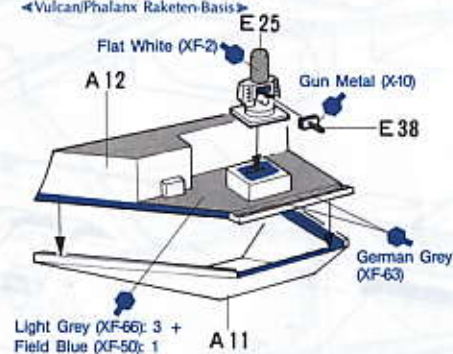

«Bow Sea Sparrow Launcher Sponson»
 «Sea Sparrow Raketen Basis»
 Mk.29 Sea Sparrow Launcher
 Mk. 29 Sea Sparrow Raketenwerfer

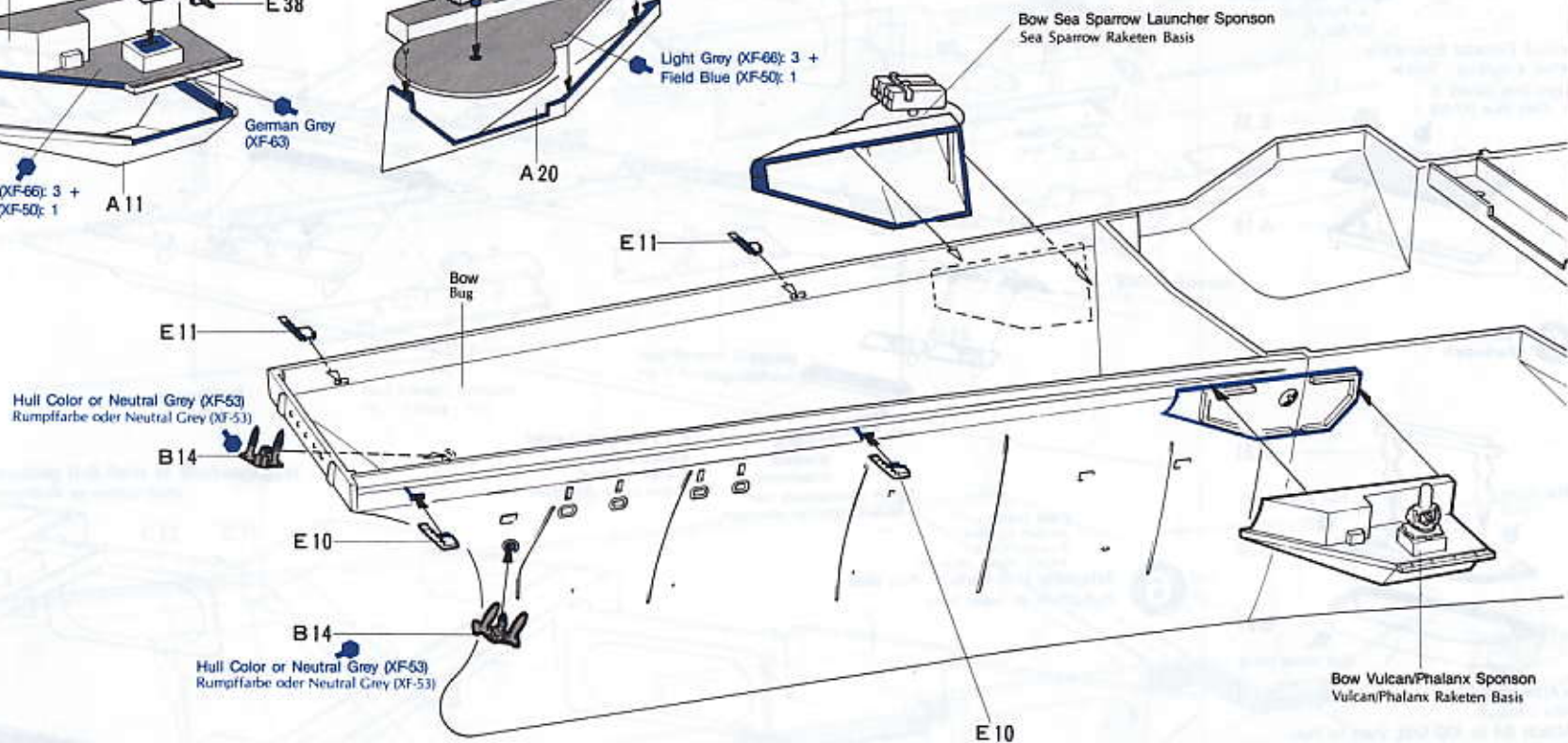
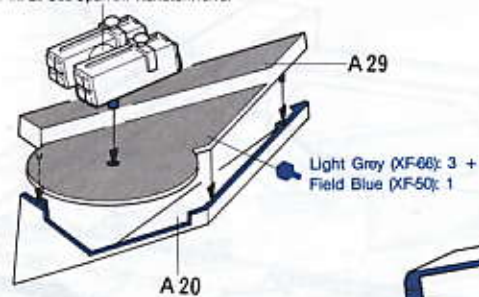

4 Assembly of Sponsons
 Zusammenbau der Raketen-Basis

«Port Sponson»
 «Port Basis»

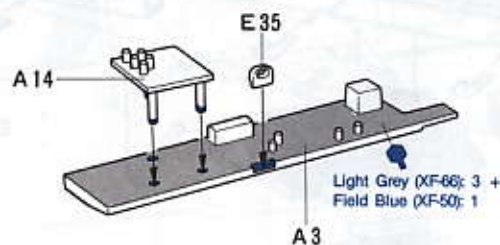

«No.3 Elevator Sponson»
 «No. 3 Aufzug - Teile»

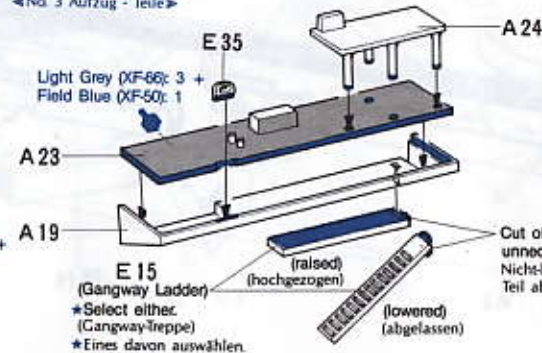

«No.1 Elevator Sponson»
 «No. 1 Aufzug - Teile»

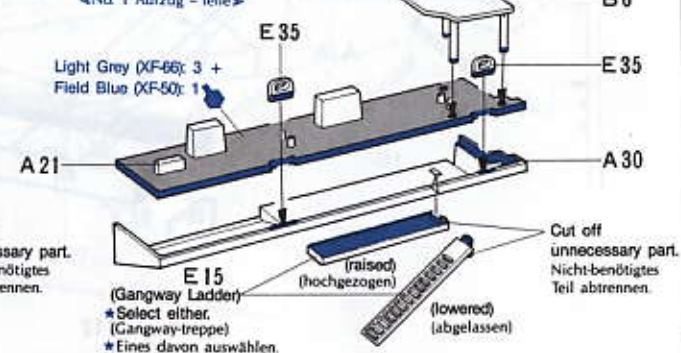

5 <Cleft Deck>
<Zwischen-Deck>

*Make 4 sets.
*4 Satz machen.



<No.4 Elevator Sponson>
<No. 4 Aufzug - Teile>

Light Grey (XF-66): 3
+ Field Blue (XF-50): 1

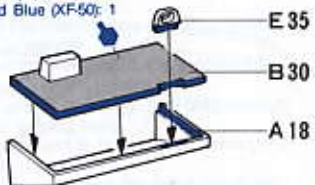

6 <Launch>
<Barkasse>



<Attaching B4>
<B4 Einbau>

Attach B4 to A10 first, then to hull.
Erst B4 an A10 anbringen, dann am Rumpf kleben.

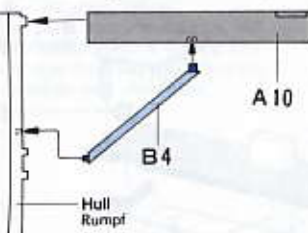

5 Attaching Port Sponsons
Einbau der Port Basen

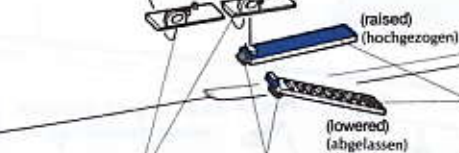
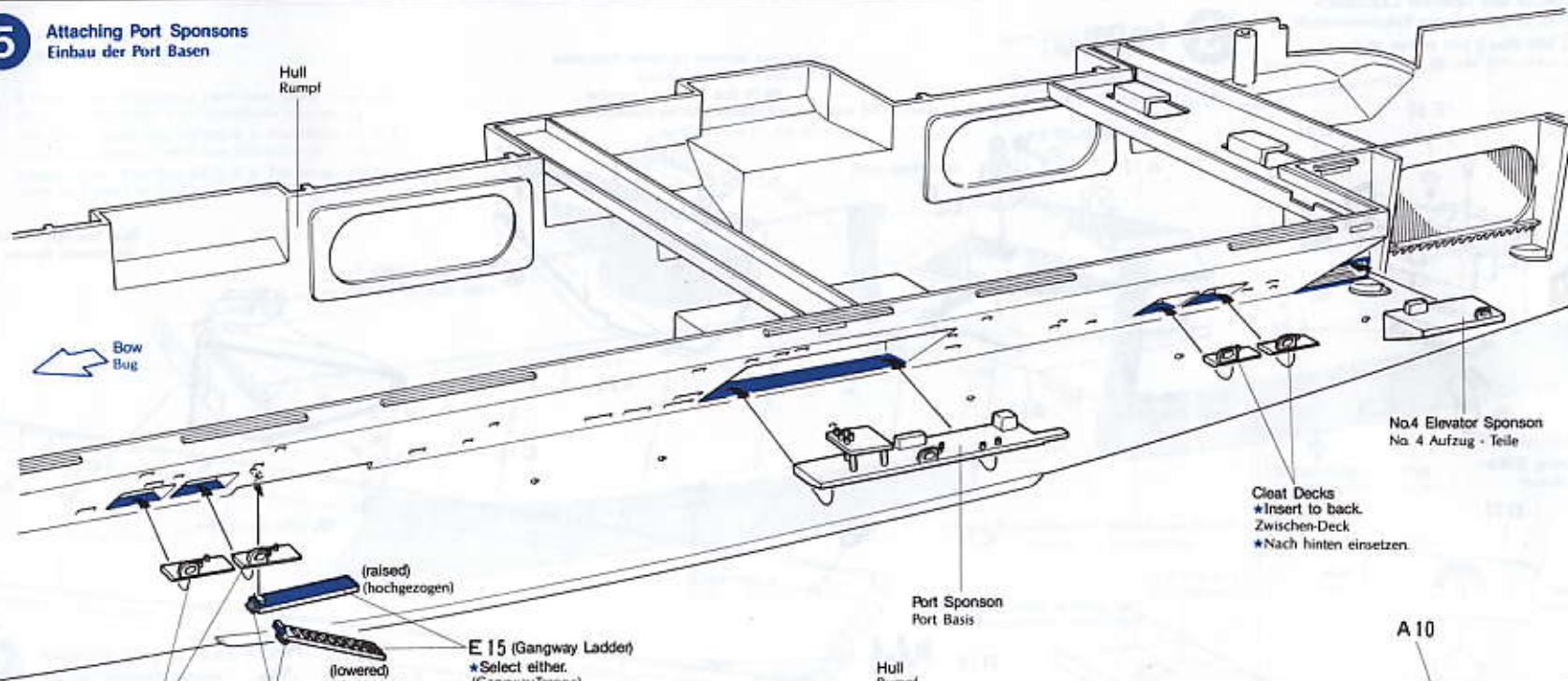

Cleft Decks
*Insert to back.
Zwischen-Deck
*Nach hinten einsetzen.

6 Attaching Hull Parts to Port Side
Rumpfteile an linker Seite

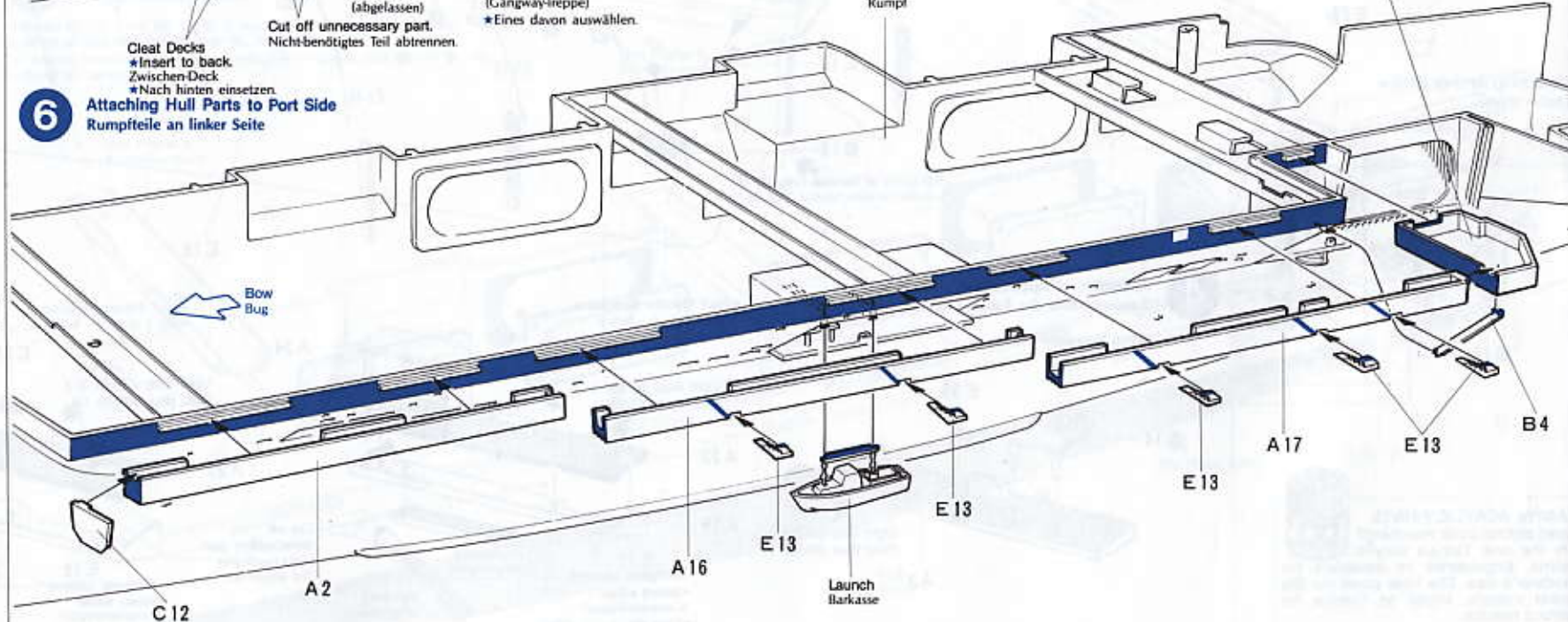

7 <No.2 Elevator Sponson>
<No. 2 Aufzug-Teil>

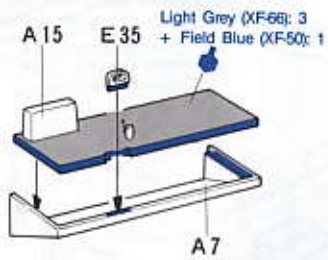

8 <Cutter>
<Kutter>

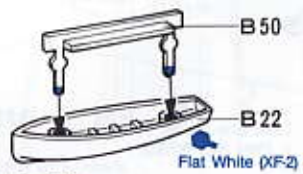

<Attaching B4>
<B4 Einbau>

Attach B4 to A22, 25 and 27 first, then to hull.
Erst B4 an A22, A25 und A27 anbringen, dann am Rumpf kleben.

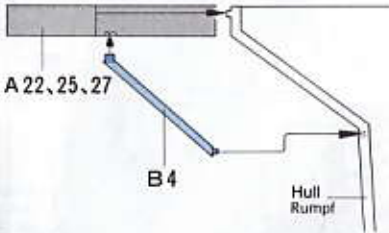

7 Attaching Elevator Sponsons
Einbau der Aufzug-Teile

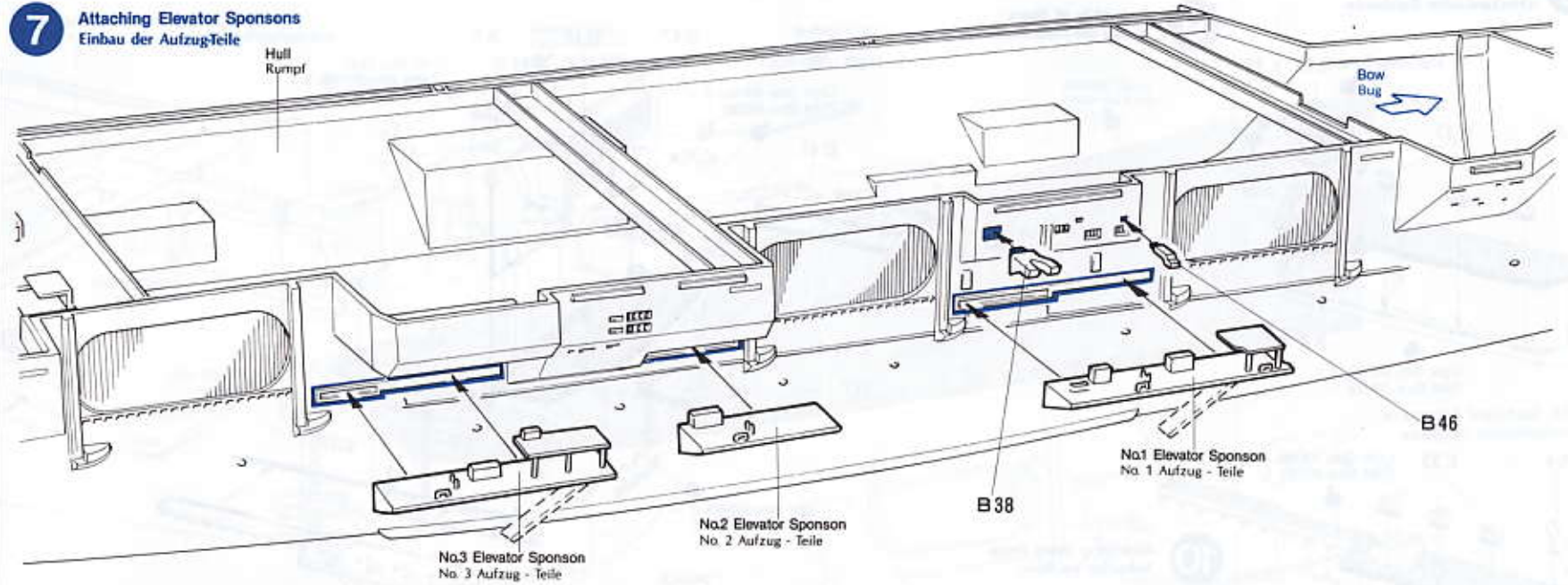

8 Attaching Hull Parts to Starboard Side
Rumpfteile an rechter Seite

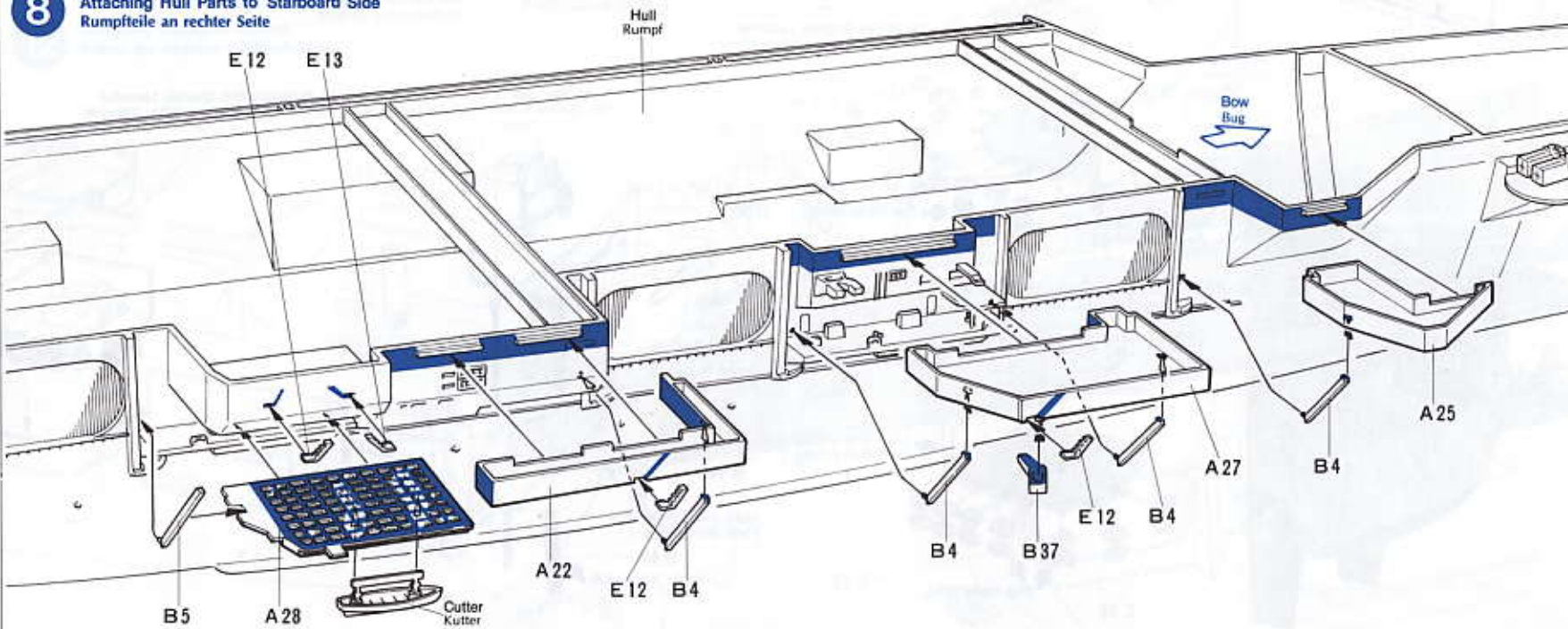

9 <Aft Port Sponson>
<Heckanbauten Backbord>

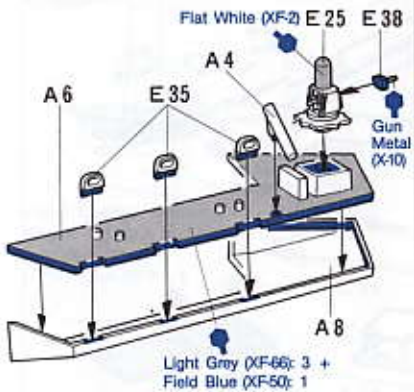

<Aft Starboard Sponson>
<Heckanbauten Starbord>

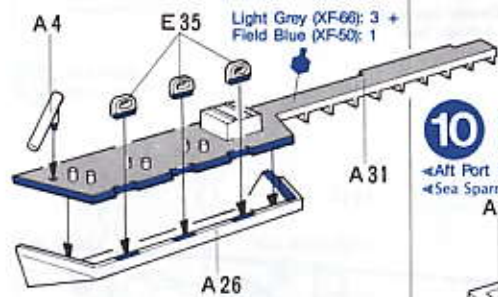

9 Assembly of Stern
Einbau der Heckanbauten

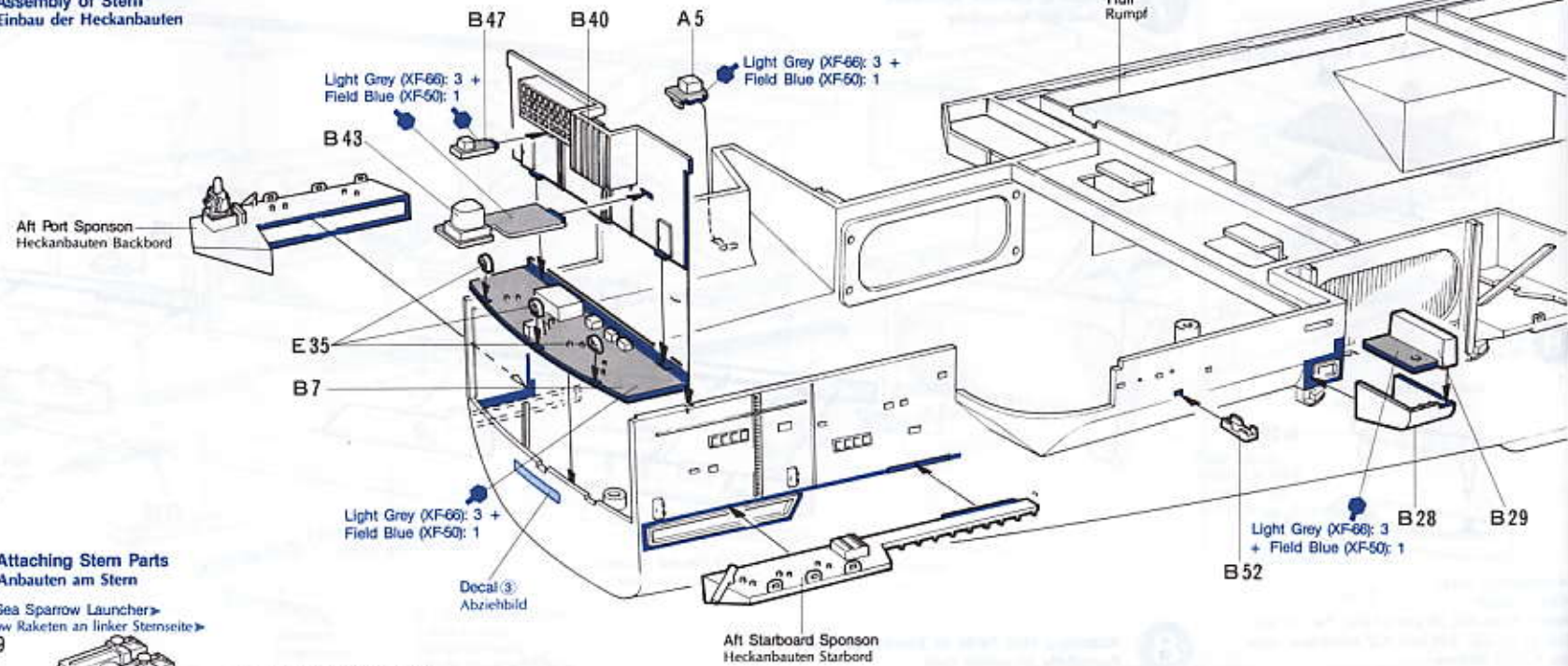

10 Attaching Stern Parts
Anbauten am Stern

<Aft Port Sea Sparrow Launcher>
<Sea Sparrow Raketen an linker Sternseite>

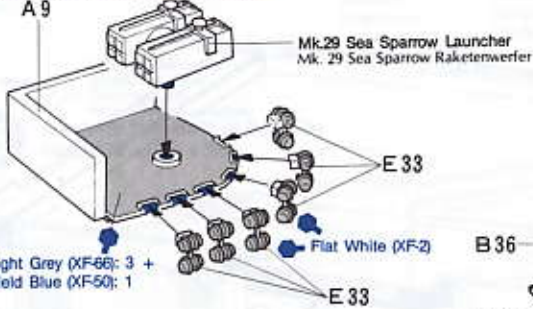

<Aft Starboard Sea Sparrow Launcher>
<Sea Sparrow Raketen an rechter Sternseite>

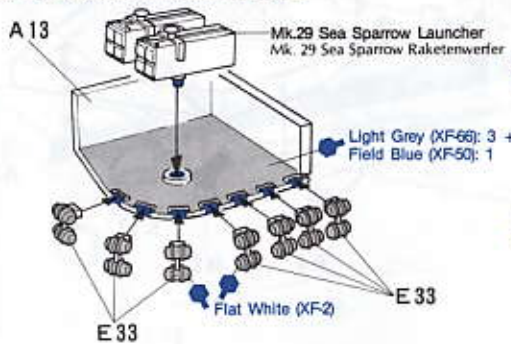

Aft Port Sea Sparrow Launcher
Sea Sparrow Raketen an linker Sternseite

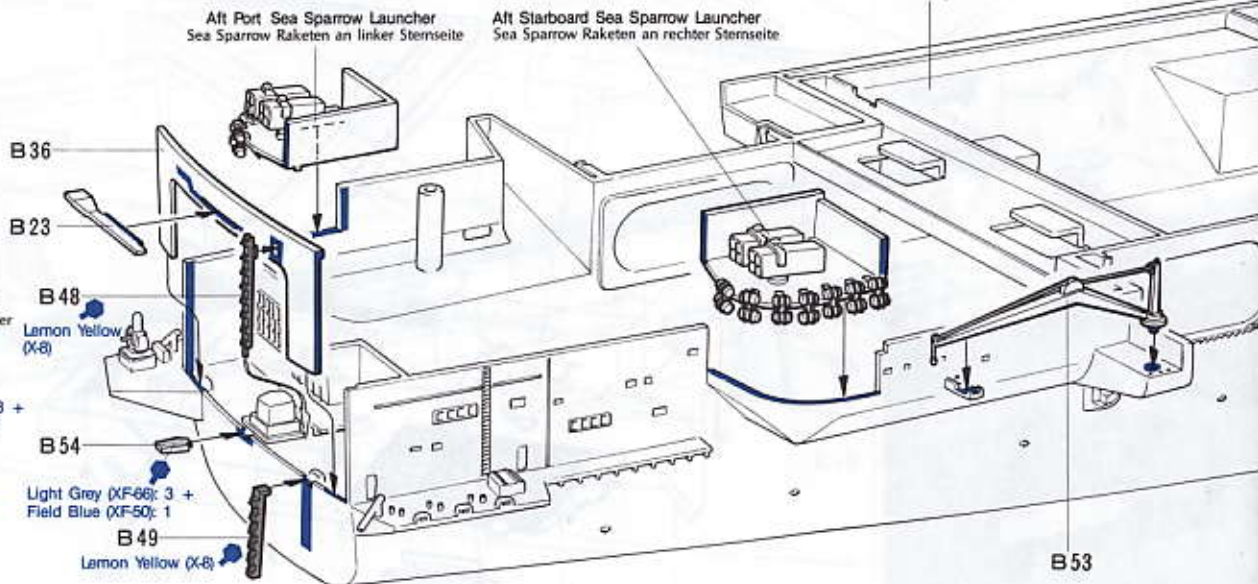

12 <Attaching B34 and 35>
<B34 and 35 Einbau>

Bore holes from inside with pin vise or awl.
Loch von innen bohren.

*Bore holes here
*Loch von innen bohren.

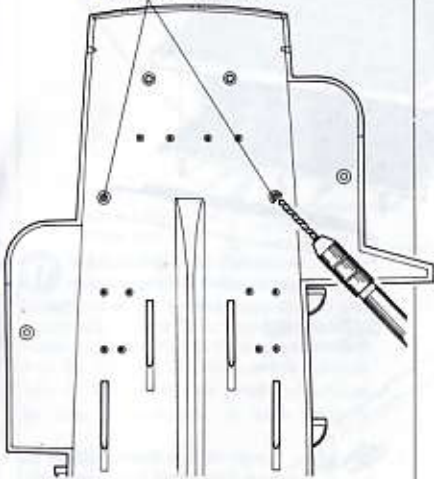

<Painting of Screw>
<Bemalung der Schiffsschraube>

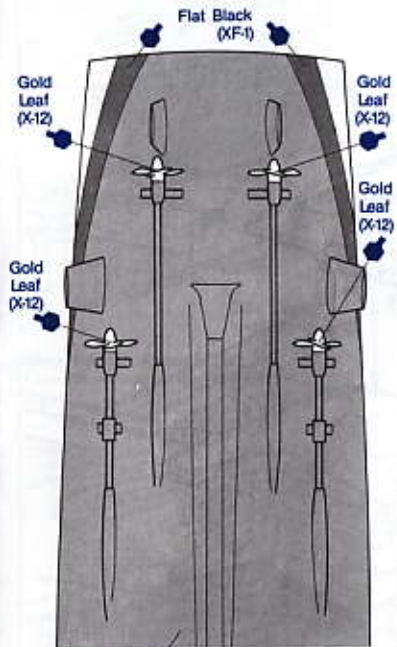

Bottom Color
Farbe des Kieles
Flat Red (XF-7): 2
+ Flat Brown (XF-10): 1

11 Attaching Inboard Screws
Einbau der inneren Schiffsschrauben

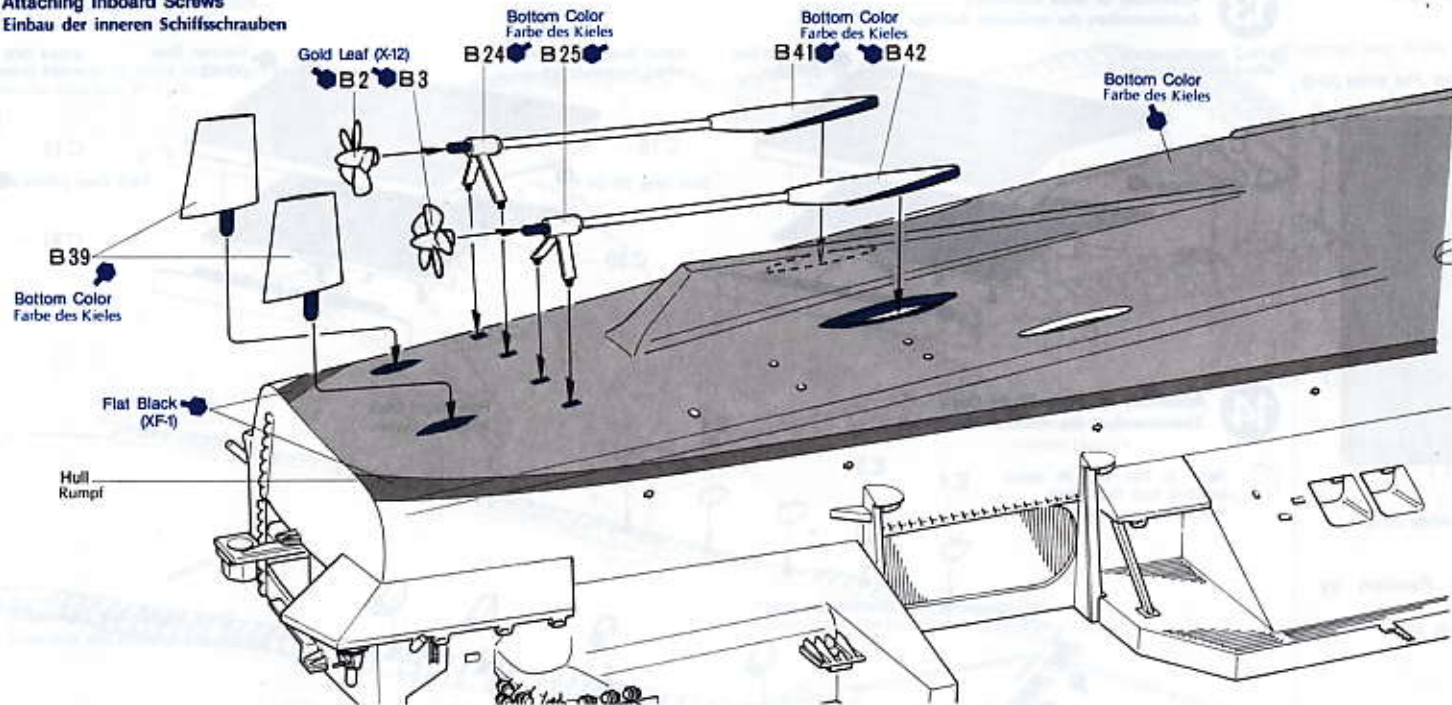

12 Attaching Outboard Screws
Einbau der äusseren Schiffsschrauben

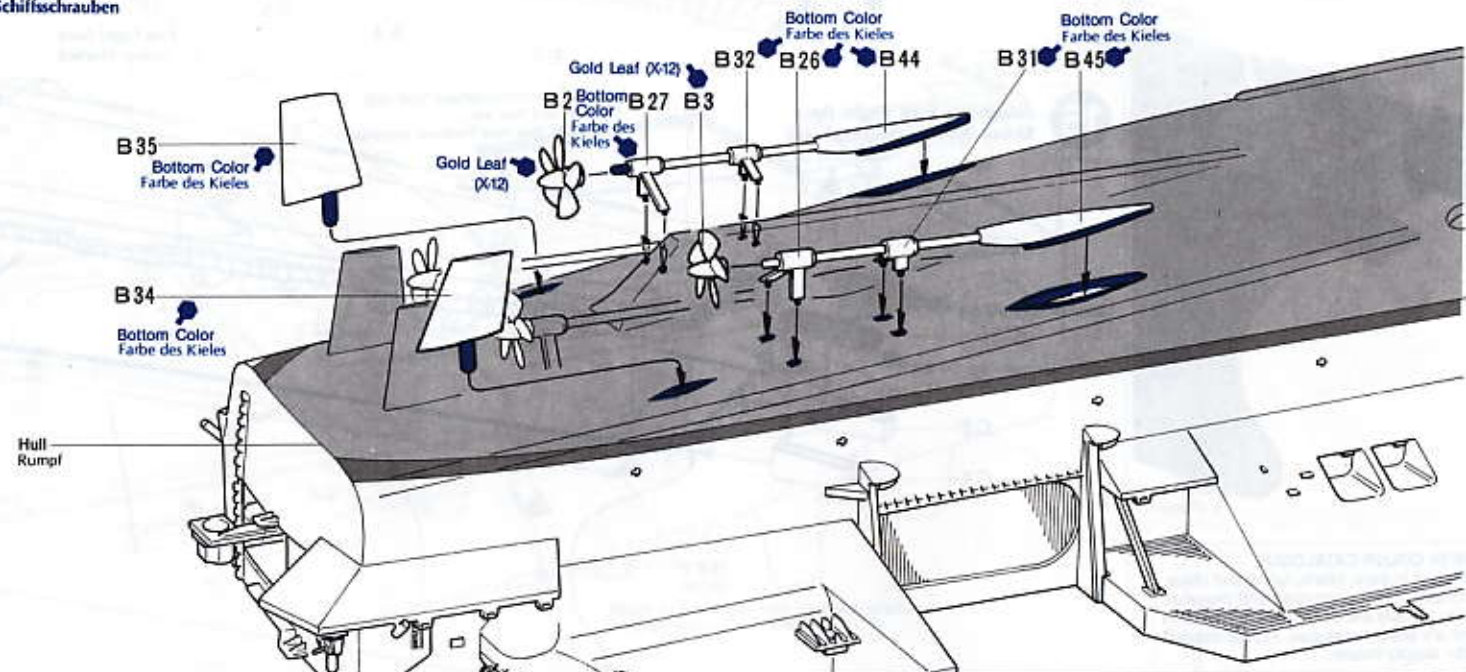

13 <Painting of Side Elevator>
<Bemalung der Seitenaufzüge>

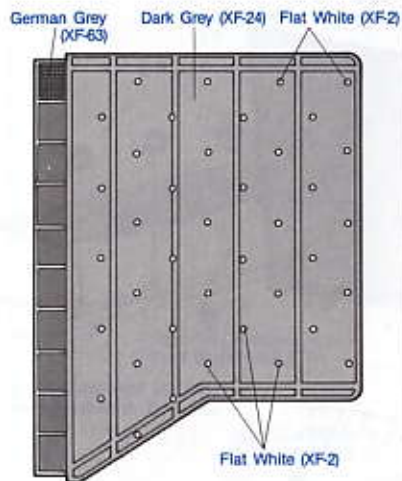

Refer to <Adding Realism by Painting> on page 24.
Siehe Vorschläge auf Seite 24.

15 <Fore Flight Deck>
<Vorderes Flugdeck>

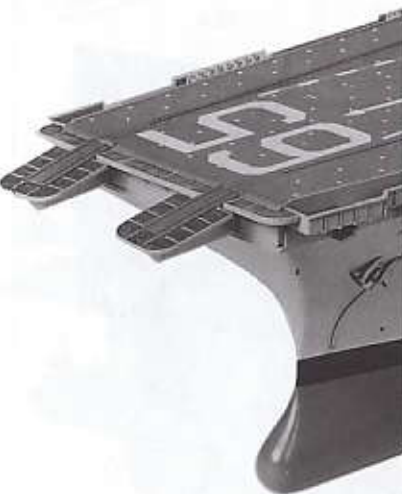

TAMIYA COLOR CATALOGUE
The latest in cars, boats, tanks and ships. Motorized, radio controlled and museum quality models are all shown in full color in Tamiya's latest catalogue. At your nearest hobby supply house.

13 Assembly of Side Elevators
Zusammenbau der seitlichen Aufzüge

<No.2 Side Elevator>
<No.2 Seitenaufzug>

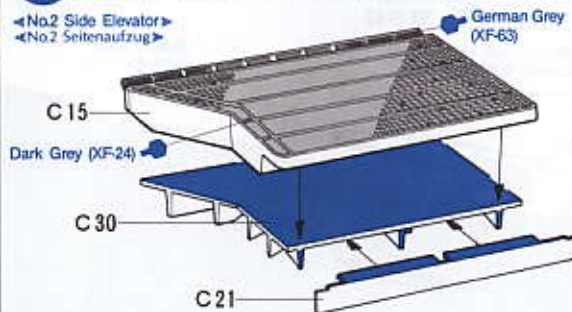

<No.3 Side Elevator>
<No.3 Seitenaufzug>



<No.4 Side Elevator>
<No.4 Seitenaufzug>

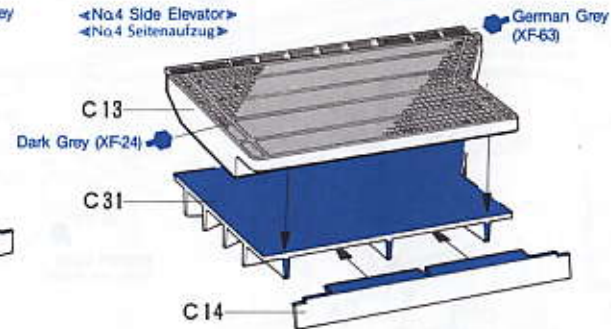

14 Assembly of Fore Flight Deck
Zusammenbau des vorderen Flugdeckes

Refer to P24 and 26 about painting fore flight deck.
Bemalung siehe auch Seite 24 + 26.

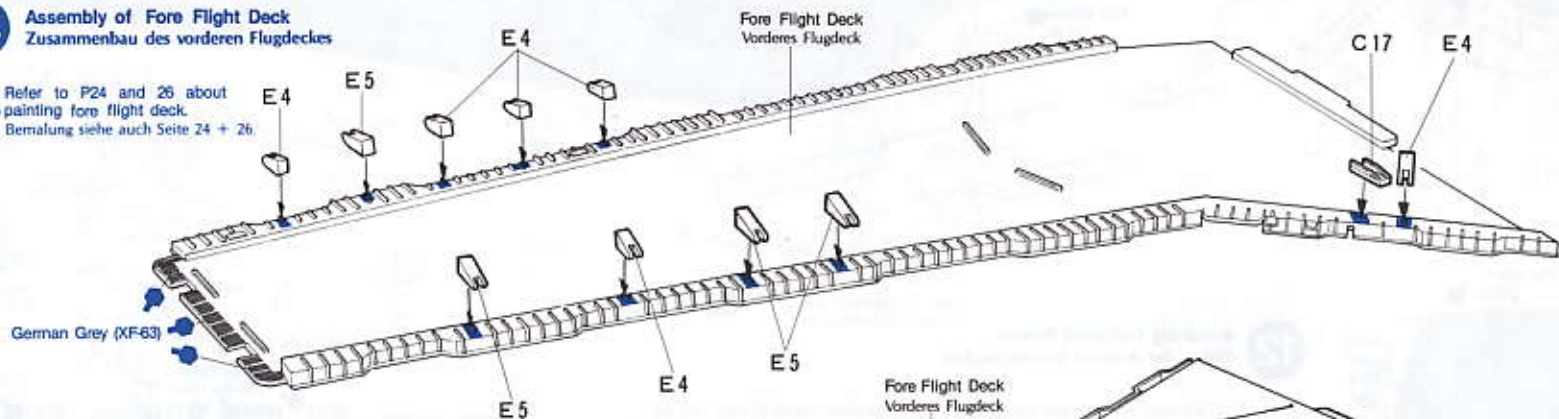

15 Attaching Fore Flight Deck
Einbau des vorderen Flugdeckes



Hull
Rumpf

16 <Nylon Line>
<Nylon Line>

Tie a nylon line and apply instant cement to knot to prevent coming loose.
Nach zusammenknoten: etwas Bomben-Kleber verhindert aufgehen des Knoten.

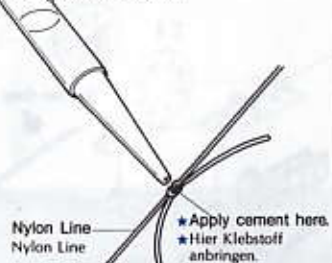

17 <Attaching Side Elevator>
<Anbringen des Seitenaufzüge>

Select either up or down position. If you attach B9, 11 and 13 in step 16, select up Position. Use B8, 10 and 12, for down position.
Teile B8, B10 und B12 für gesenkte Aufzüge.
Teile B9, B11 und B13 für gehobene Aufzüge.
So oder so einbauen, je nach Wunsch.

(Up Position) Attach to flight deck.
Gehobener Aufzug am Flugdeck anbringen.
Fix with cellophane tape until cement has set.
Mit Tesa zum Trocknen festhalten.

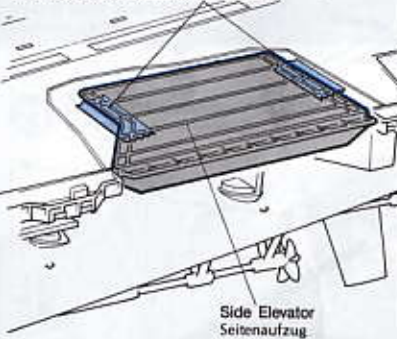

(Down Position) Attach to hull.
Gesenkter Aufzug am Rumpf anbringen.

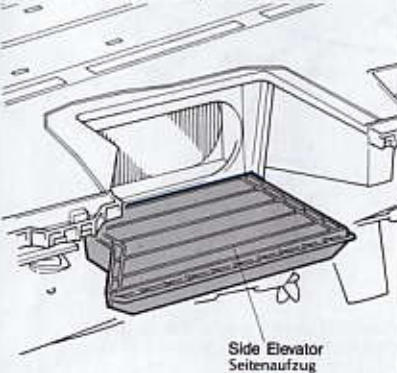

16 Assembly of Aft Flight Deck
Am hinteren Flugdeck anbringen

Refer to P24 and 26 about painting aft flight deck.
Bemalung siehe Seite 24 + 26

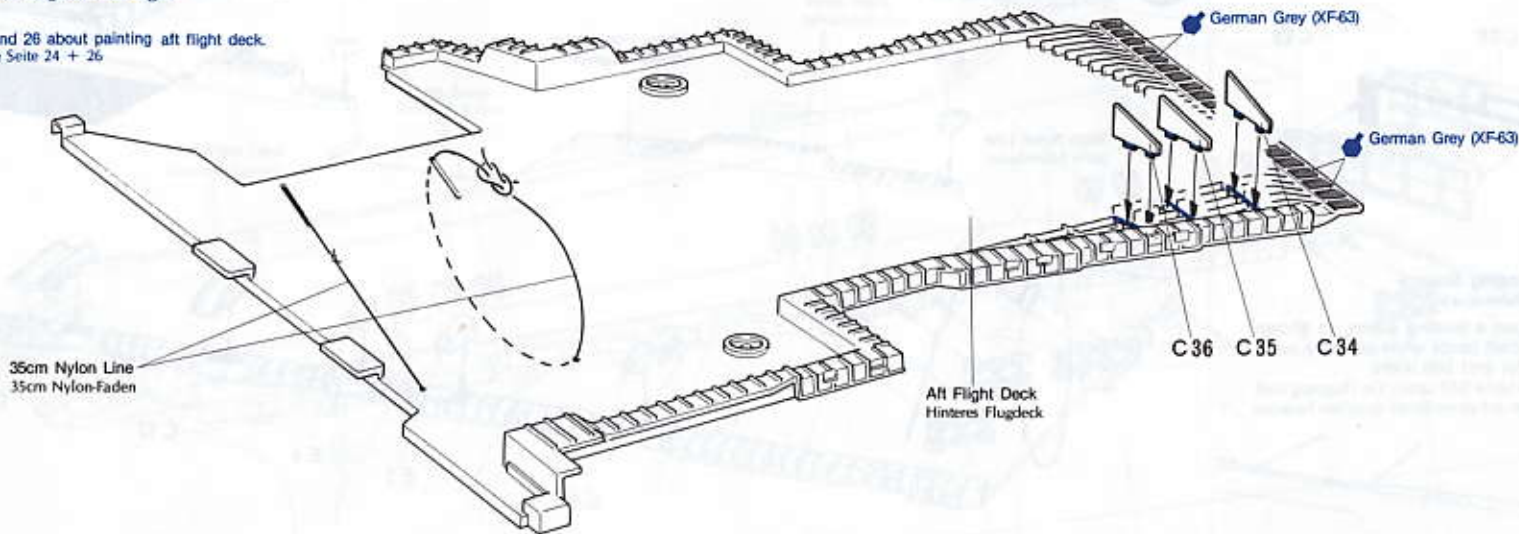

17 Attaching Aft Flight Deck
Einsetzen des hinteren Flugdeckes

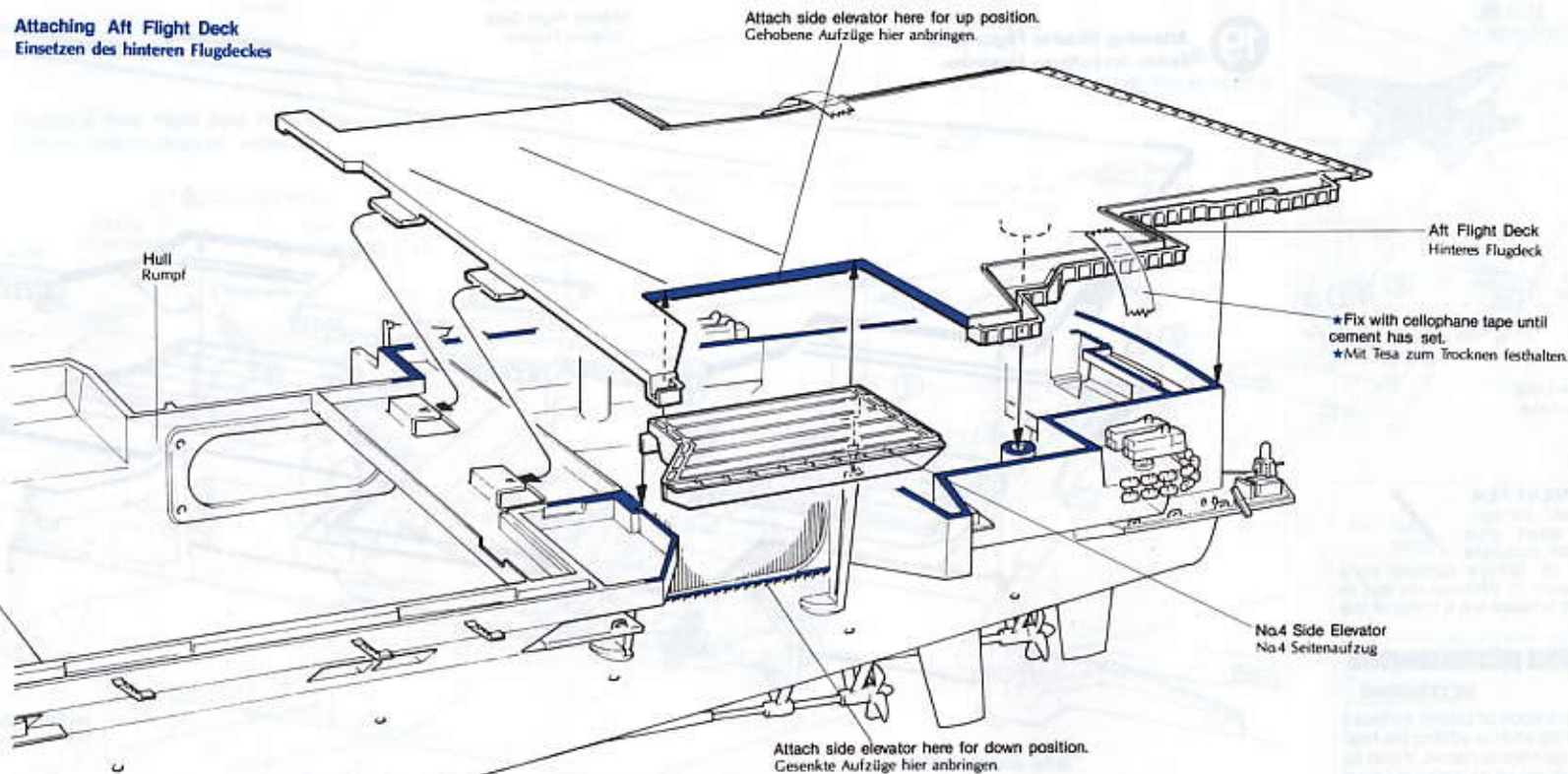

18 <Side Radar>
<Seiten-Radar>

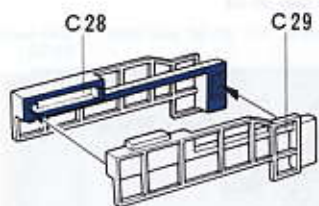

19 <Landing Scene>
<Landeszene>

To reproduce a landing scene, as shown below. Aircraft lands while aiming a point between 1st and 2nd wires.
Landeszene siehe Bild unten. Ein Flugzeug zielt beim Landen auf einen Punkt zwischen Fanleine 1 und 2.

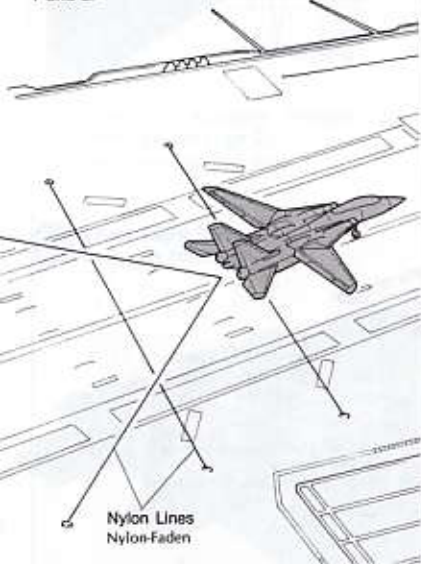

TAMIYA CEMENT PEN
A handy, self-contained pencil sized glue dispenser for accurate application of Tamiya cement right where you want it. Will not dry out in pen. Cement smears are a thing of the past.

Tamiya rubbings polishing compound
Used for preparation of plastic surfaces prior to painting and for adding the final polishing to painted surfaces. It can be used to polish out paint overspray from the base coat for a perfect finish.

18 Assembly of Midship Flight Deck
Aufbauten am Flugdeck

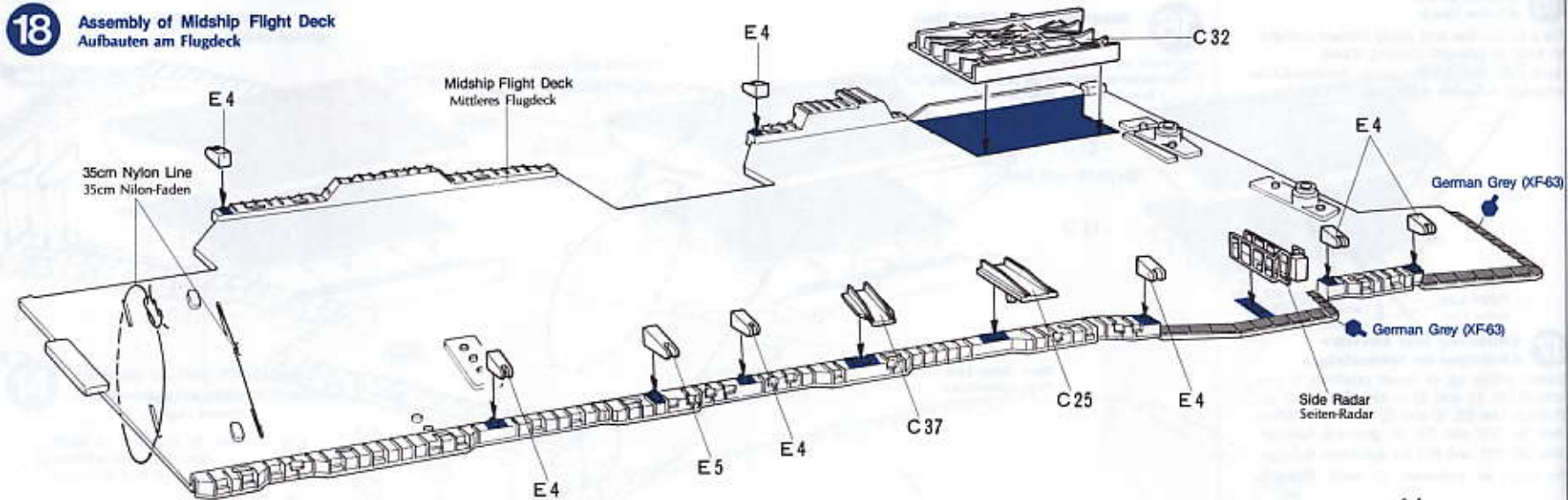

19 Attaching Midship Flight Deck
Einbau des mittleren Flugdecks

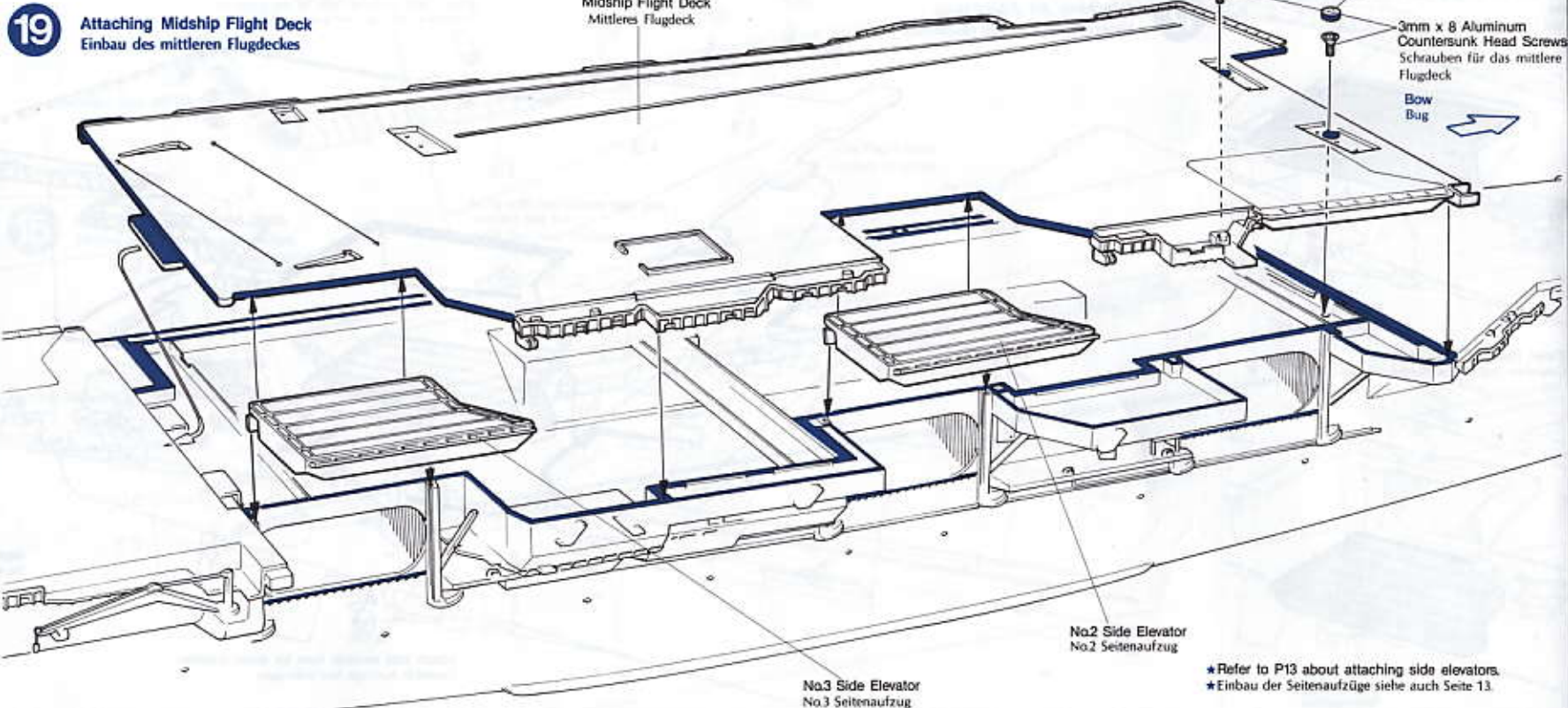

★Refer to P13 about attaching side elevators.
★Einbau der Seitenaufzüge siehe auch Seite 13.

20 <Hose Reel>
<Schlauch-Rollen>

★ Make 24 sets
★ 24 Satz machen

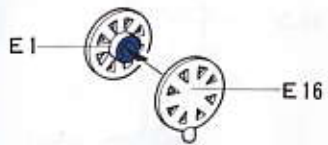

20 Attaching Fore Flight Deck Parts to Port Side
Teile am vorderen Flugdeck - linke Seite

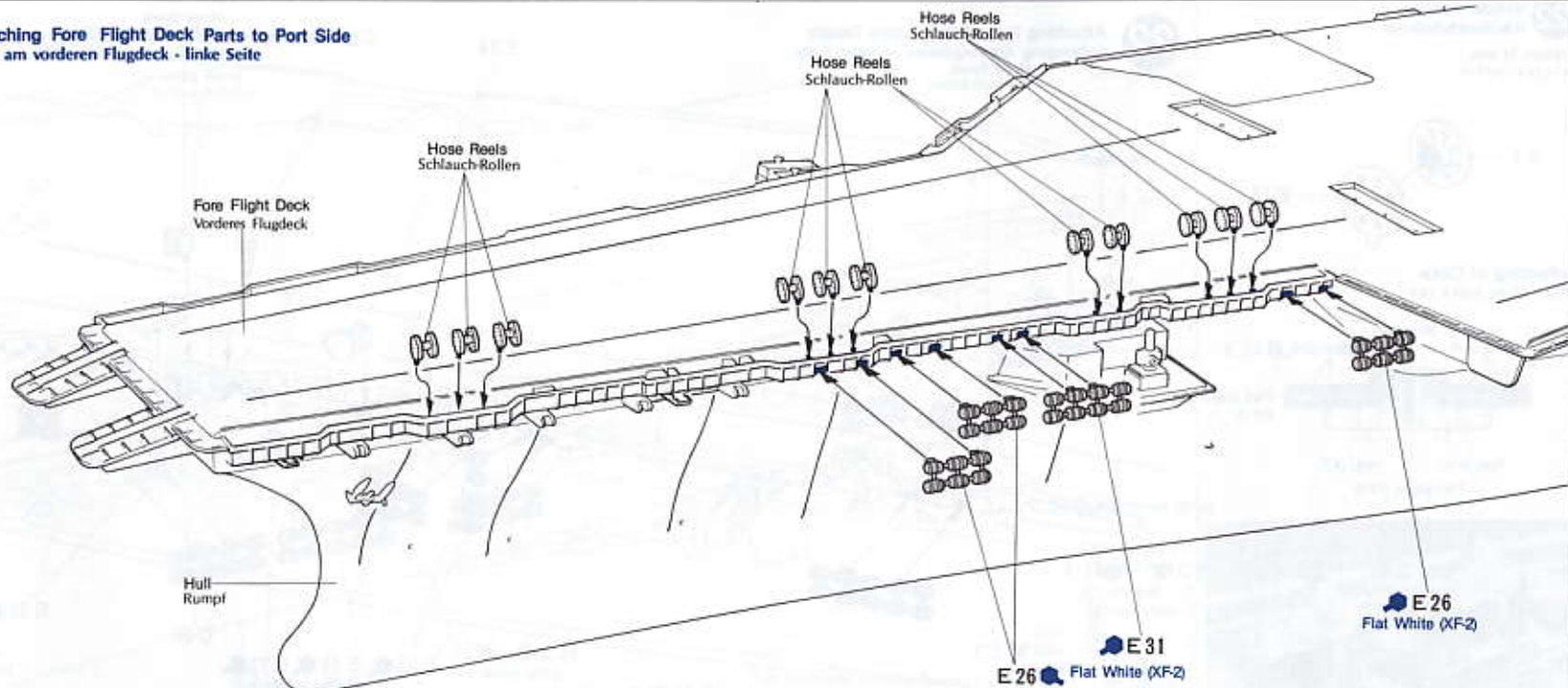

21 <Jet Blast Deflector>
<Düsenstrahl-Abweiser>

21 Attaching Fore Flight Deck Parts to Starboard Side
Teile am vorderen Flugdeck - rechte Seite

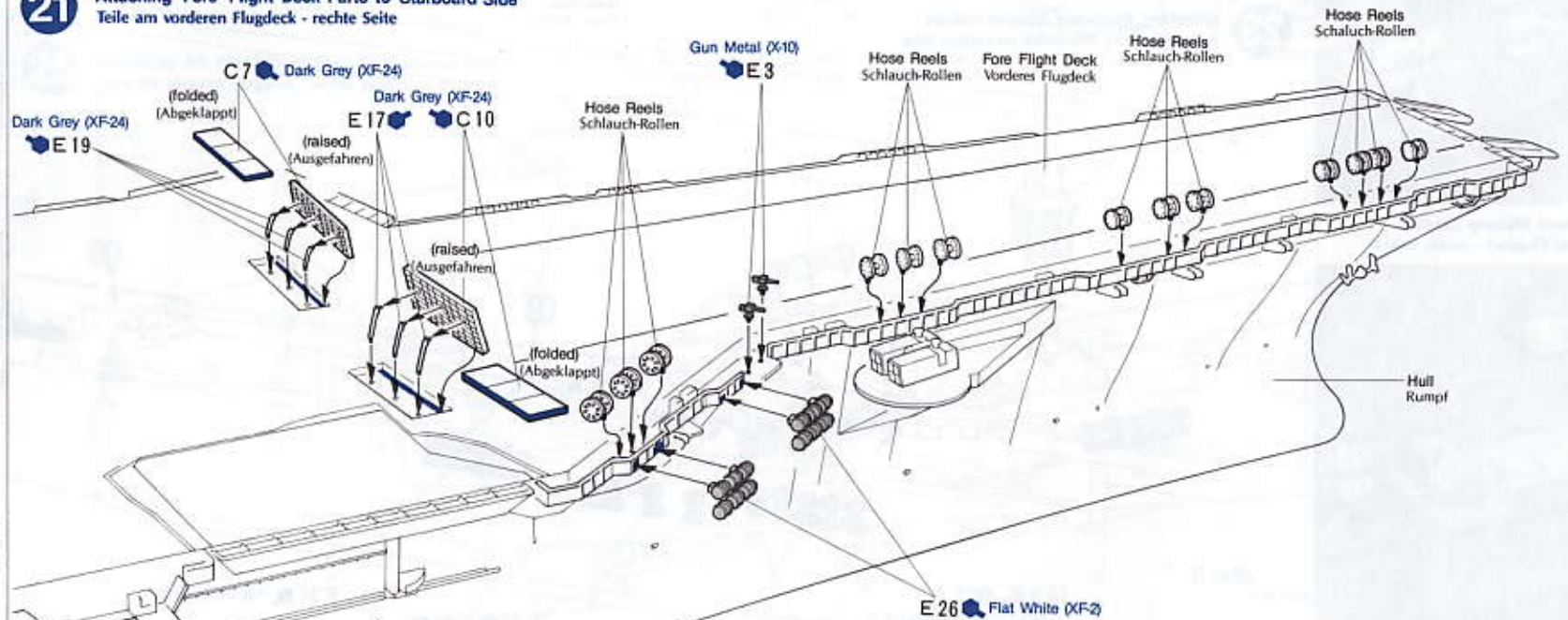

22 «Hose Reel»
«Schlauch-Rollen»

★Make 14 sets.
★14 Satz machen



«Painting of G24»
«Bemalung von C24»

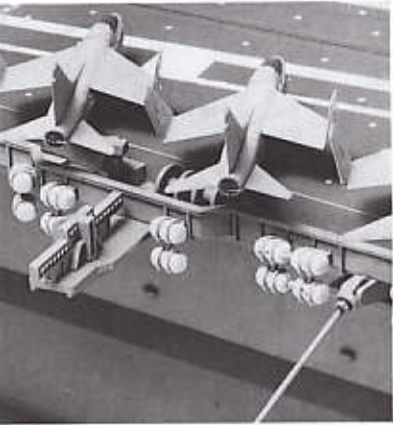
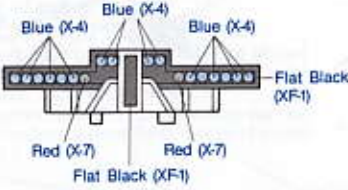

23 «Starboard Midship Details»
«Mittleres Flugdeck - rechte Seite»

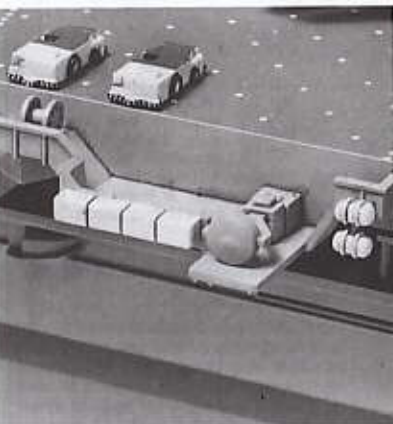

22 Attaching Port Midship Deck Details
Anbringung des Flugdeckes an linker Seite

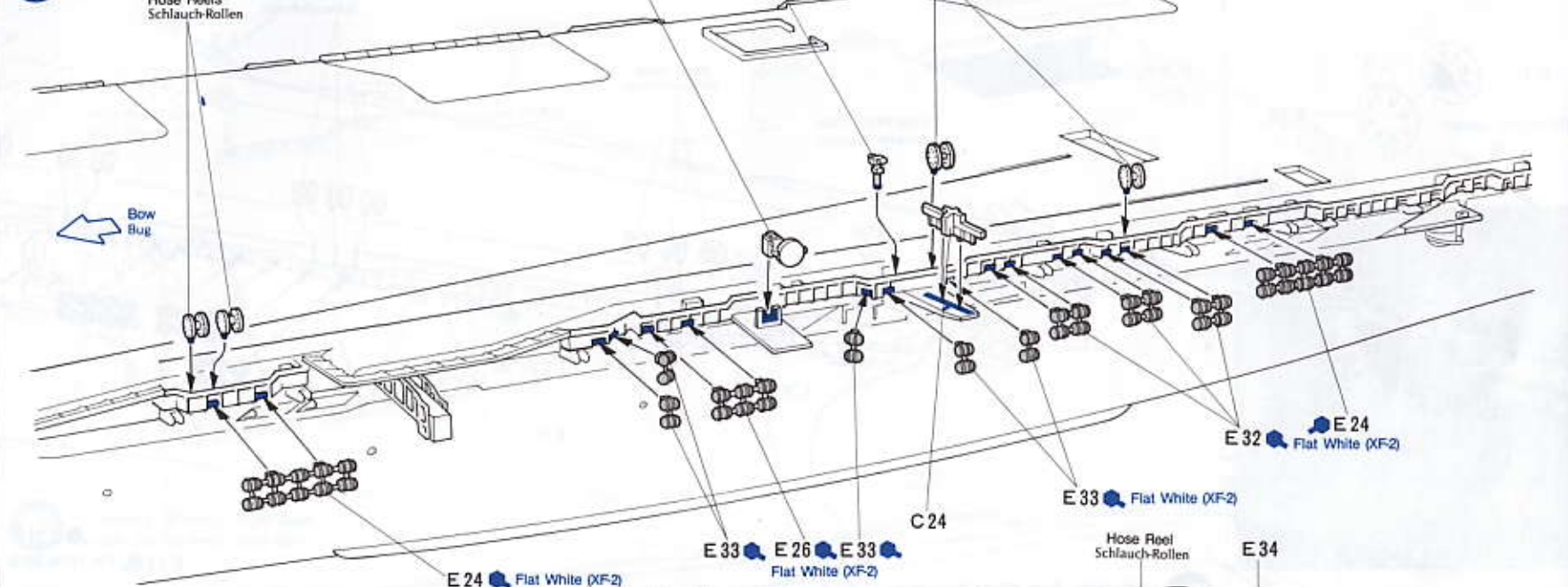

23 Attaching Starboard Midship Details
Anbringung des Flugdeckes an rechter Seite

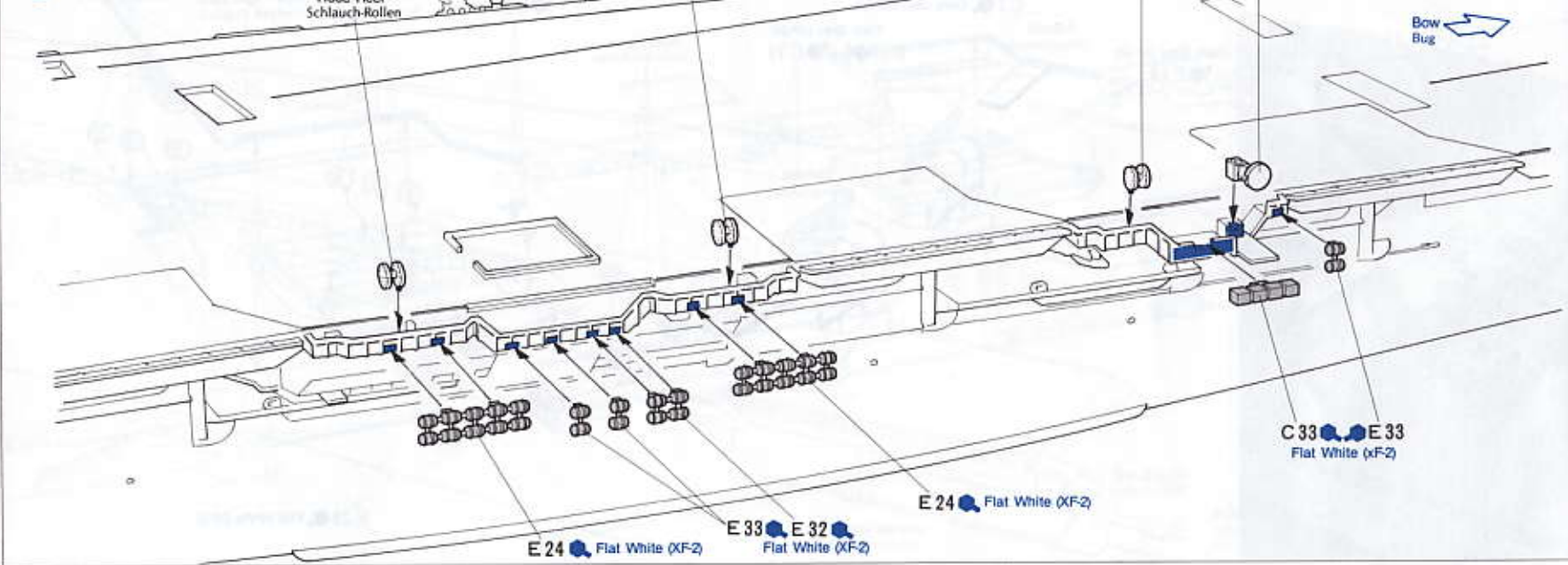

25 <Full Automatic Landing System>
<Vollautomatisches Landesystem>

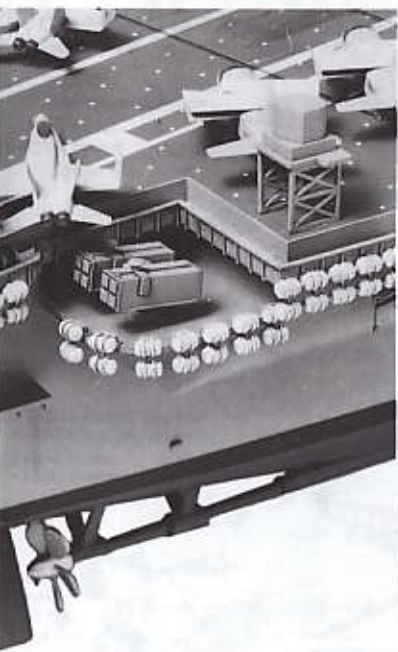
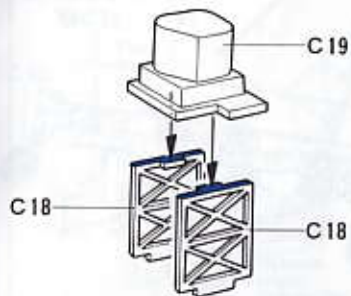

<Mk.7 Barricade Stanchion>
<Mk.7 Fangnetz>

Make barricade net as shown below, if you raise supports.

Wenn Fangsäulen ausgefahren eingebaut werden, ein Fangnetzes - wie unten gezeigt - machen.

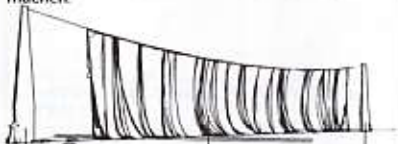

Support (C2) Fangsäule Barricade Net Fangnetz Support (C3) Fangsäule

24 Attaching Aft Flight Deck Parts to Port Side
Teile am hinteren Flugdeck - linke Seite

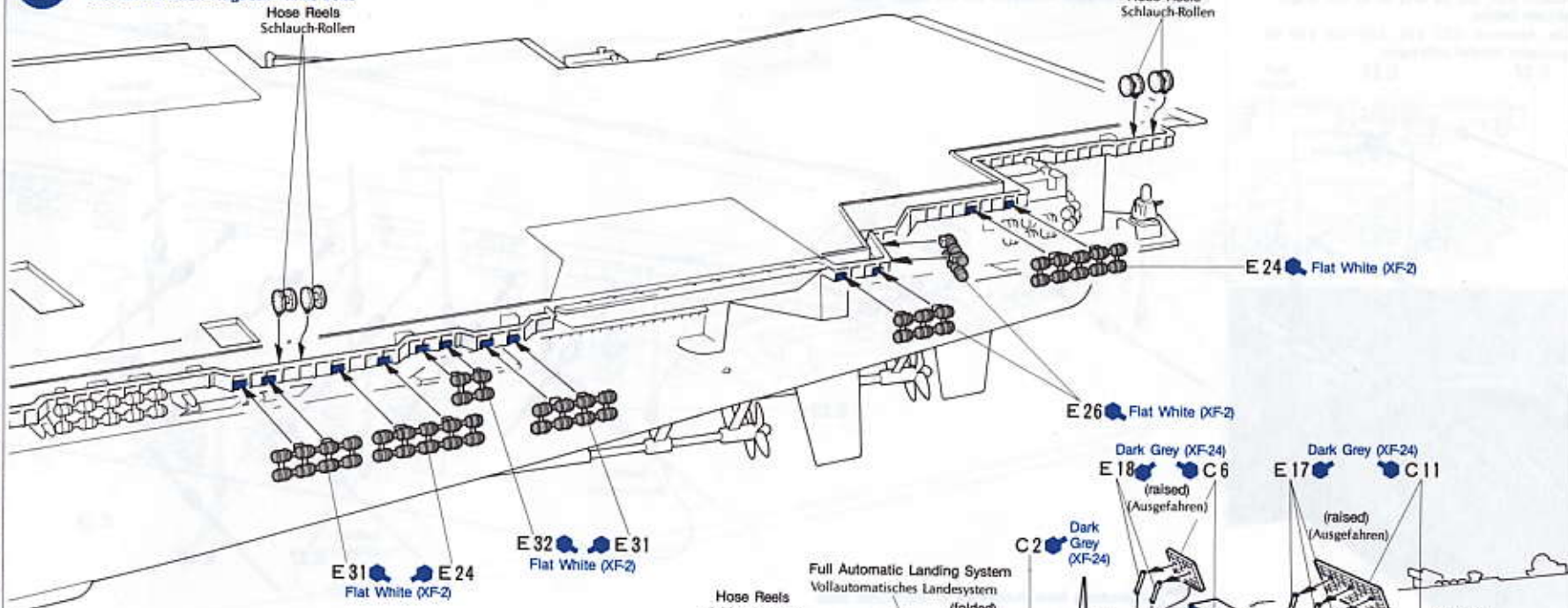

25 Attaching Aft Flight Deck Parts to Starboard Side
Teile am hinteren Flugdeck - rechte Seite

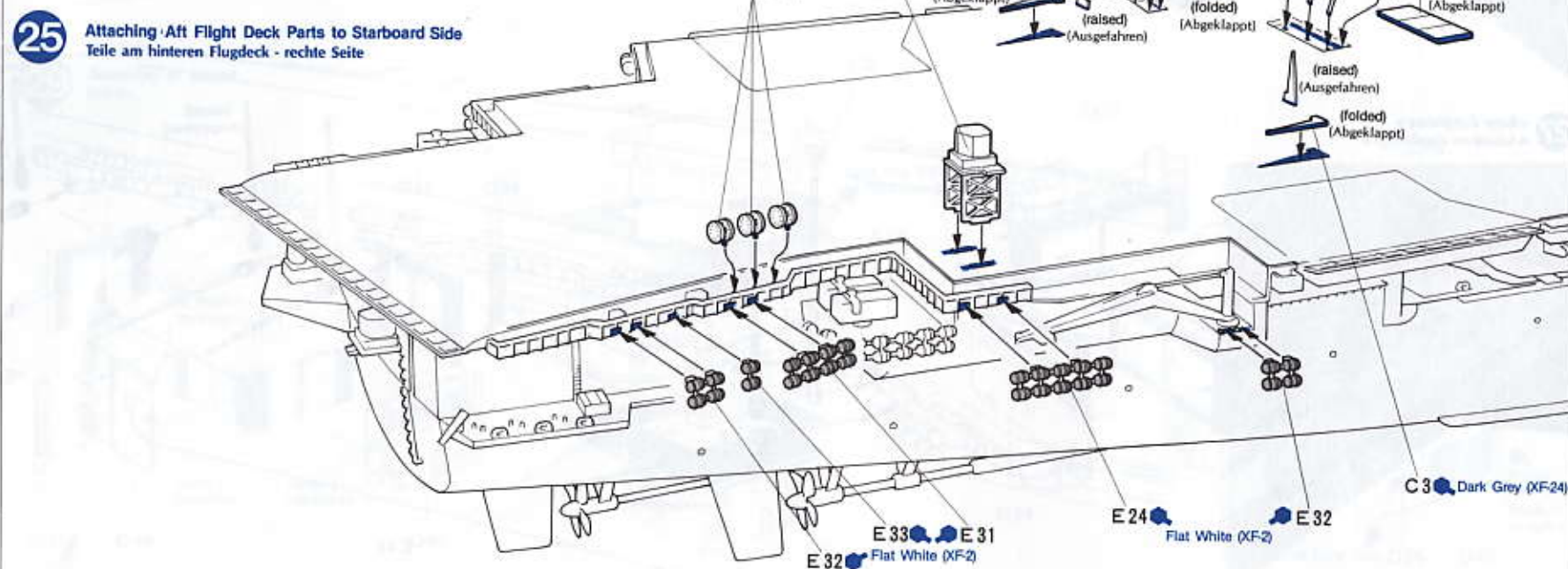

26 <Down Position of Antennas>
<Antennen abgeklappt>

Attach E27, 29, 39 and 40 at the angle shown below.
Die Antennen E27, E29, E39 und E40 im gezeigten Winkel anbringen.

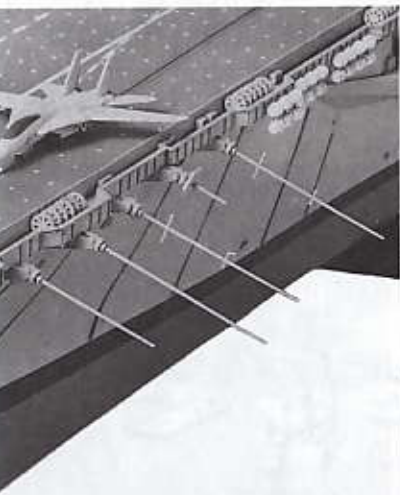
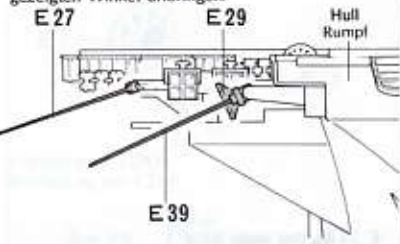

27 <Bow Antennas>
<Antennen abgeklappt>

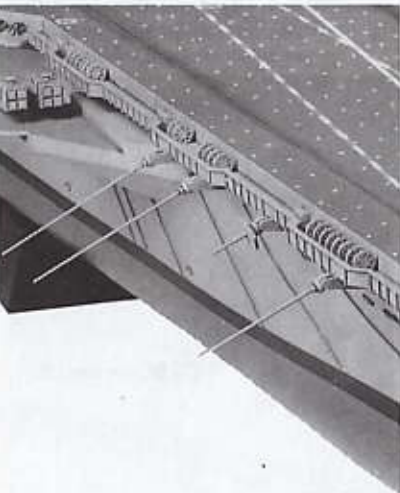

26 Attaching Bow Antennas to Port Side
Abgeklappte Antennen auf der linken Seite

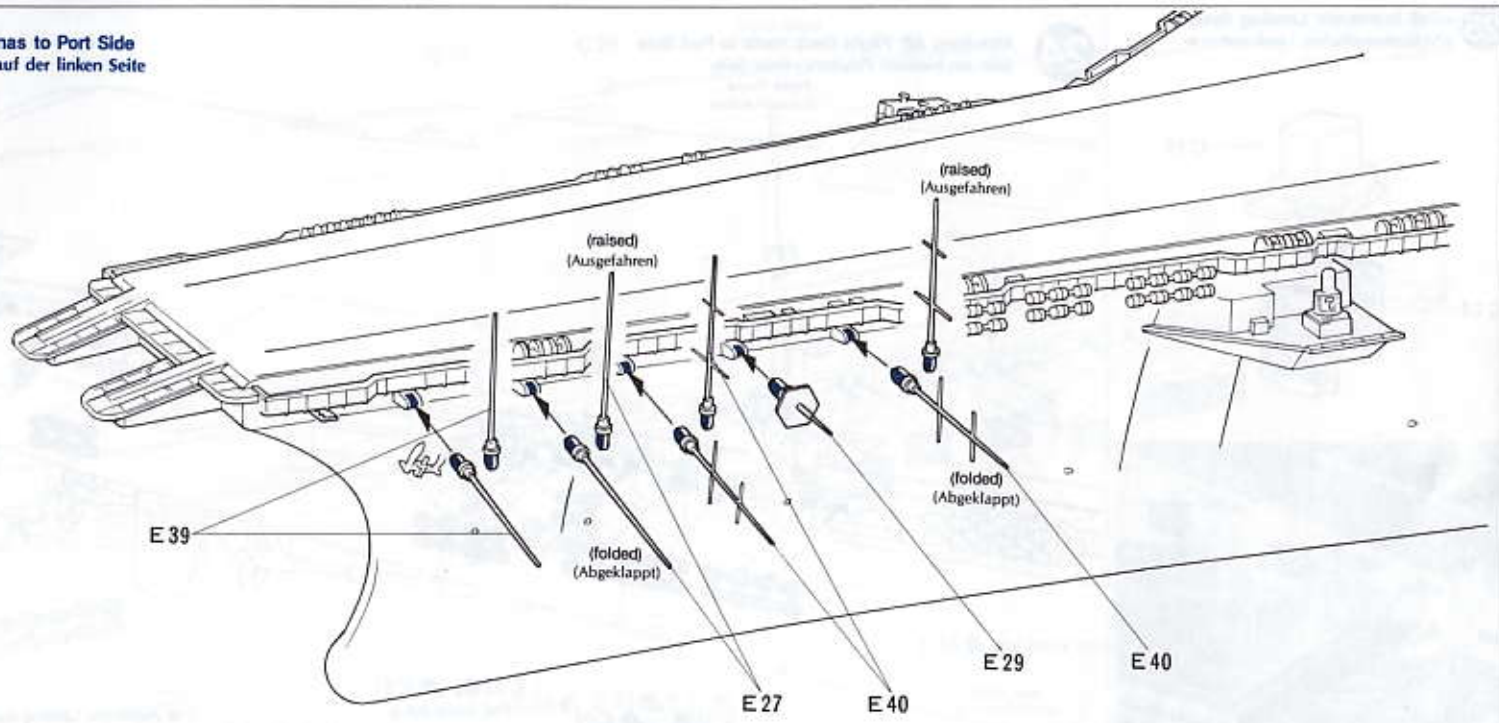

27 Attaching Bow Antennas to Starboard Side
Abgeklappte Antennen auf der rechten Seite

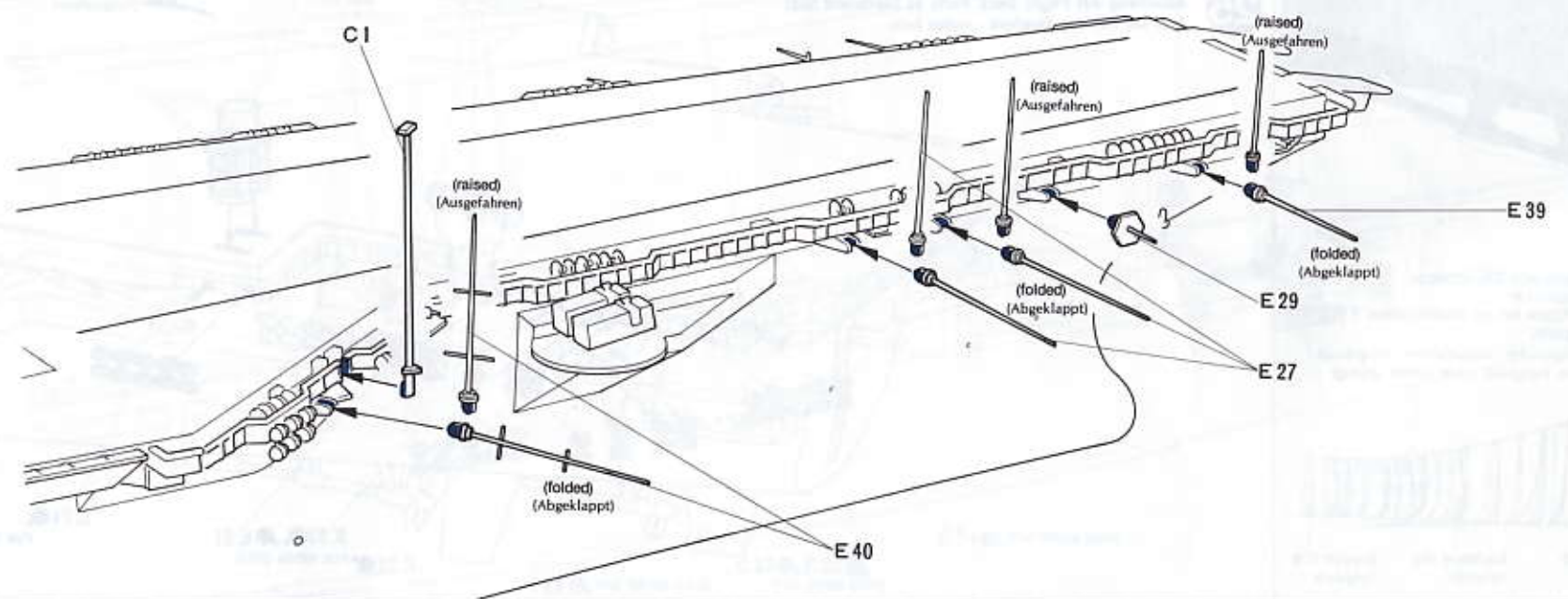

◀NS-50 Mobile Crane▶
◀NS-50 fahrbarer Kran▶

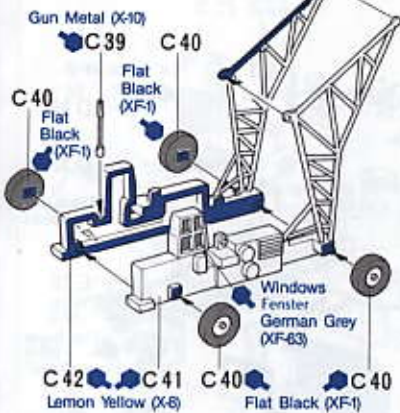

◀MD-3A Tow Tractor▶
◀MD-3A Zugmaschine▶

★Make 8 sets.
★8 Satz machen.

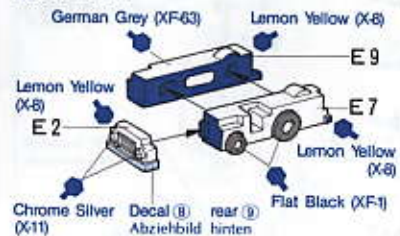

◀MB-1A Crash Truck▶
◀MB-1A Rettungswagen▶

★Make 2 sets.
★2 Satz machen.

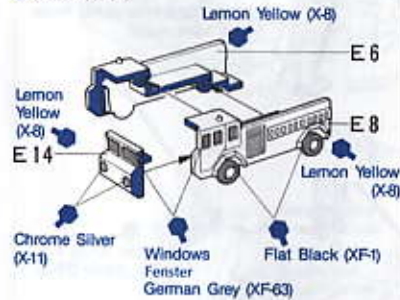

TAMIYA FARBKATALOG IN DEUTSCHER SPRACHE

Letzte Neuheiten von Autos, Booten, Tanks und Schiffen. Im Tamiya-Katalog in deutscher Sprache sind alle Modelle, ob Motorisierte, Ferngesteuerte oder Museum-Qualitates-Modelle, farbig Abgebildet.

28 Attaching Antennas
Antennen Einbau

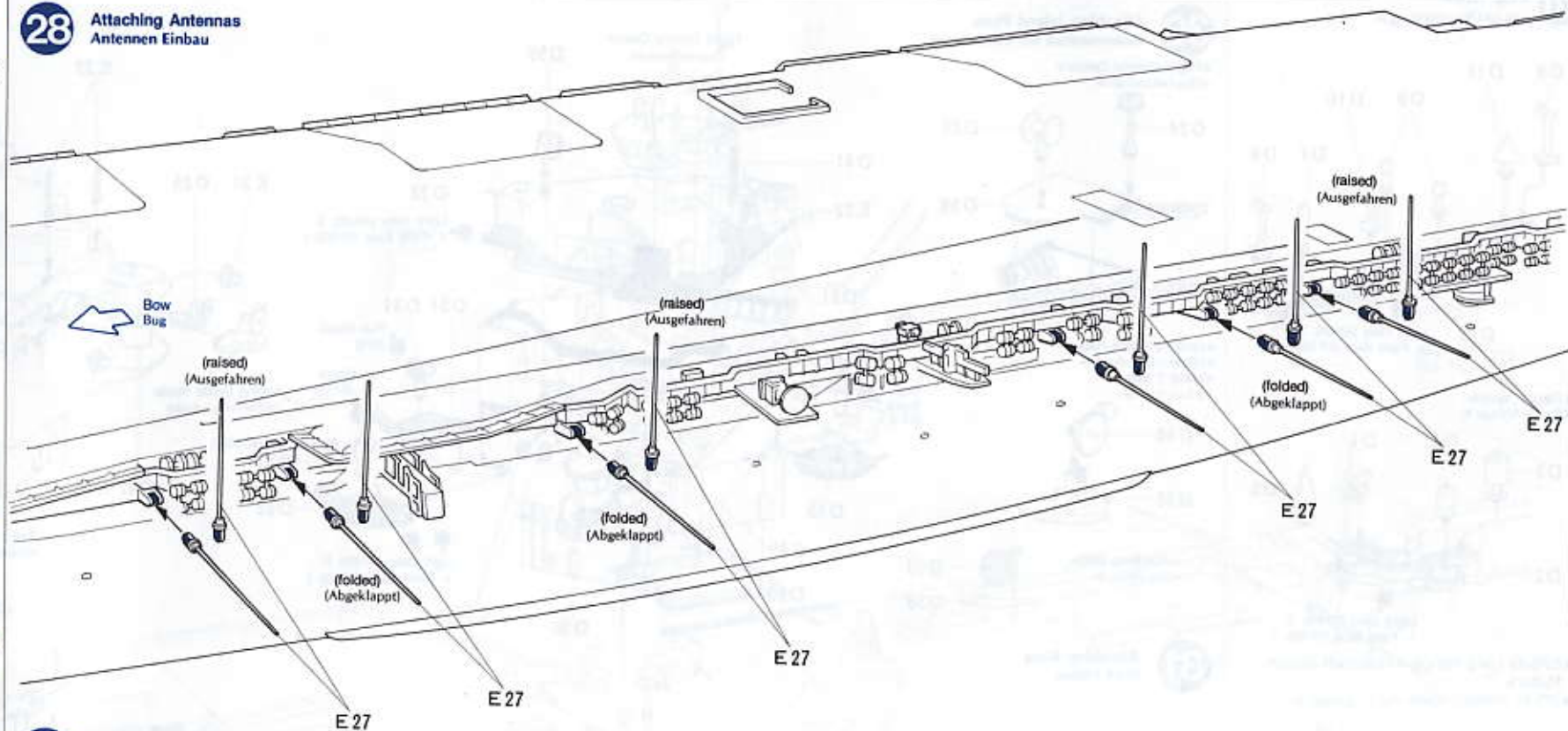

29 Assembly of Island Bridge
Assemblierung der Inselbrücke

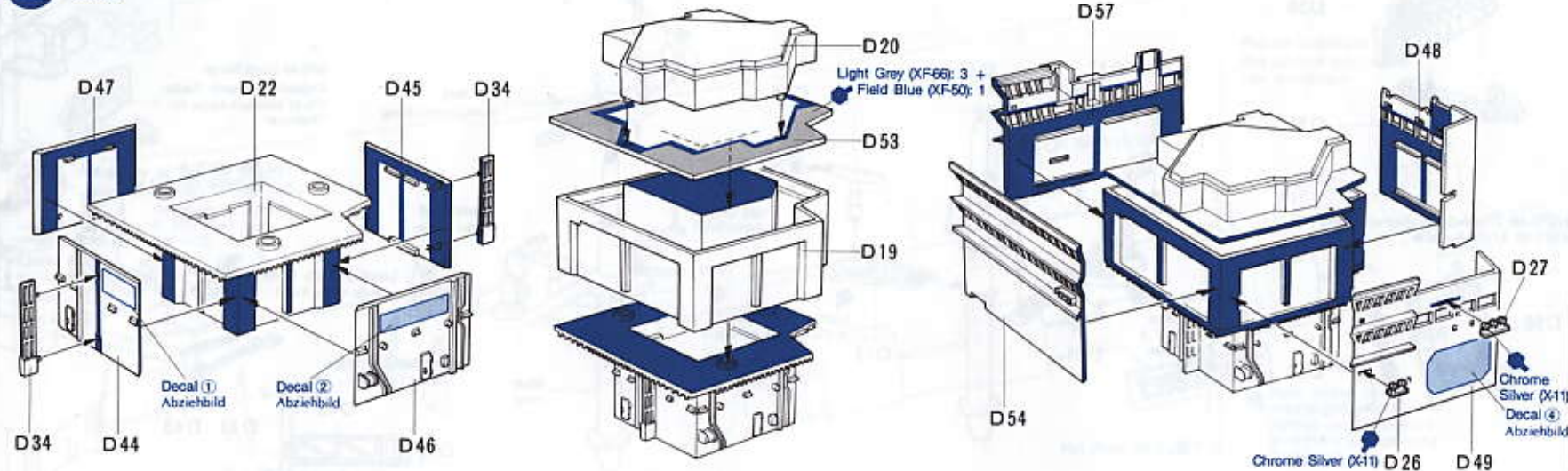

31 <Top Yard>
<Mast-Überstückerung>

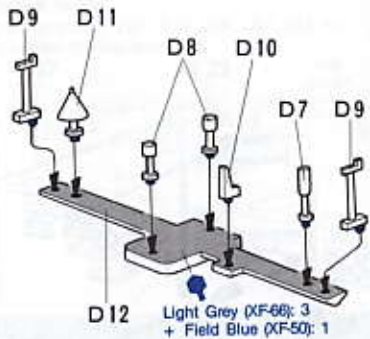

<Radar Yard>
<Radar-Anlage>

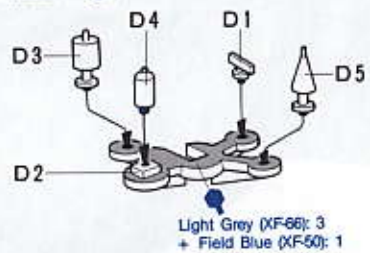

<SPS-49 Long Range Antiaircraft Search Radar>
<SPS-49 Weitsuch-Radar für Flugzeuge>

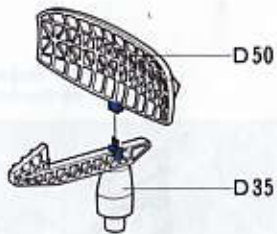

<SPS-48 Three-dimensional Radar>
<SPS-48 3-Dim-Radar>

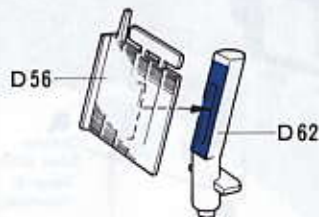

30 Attaching Island Parts
Zusammenbau der Brückenteile

<Flight Control Center>
<Flug-Leitzentrals>

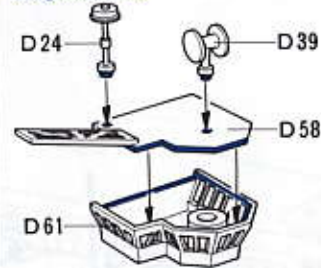

<Landing Guide Radar>
<Lande-Anflug-Radar>



<Attaching D60>
<D60 Einbau>

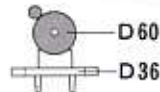

31 Attaching Mast
Mast Einbau

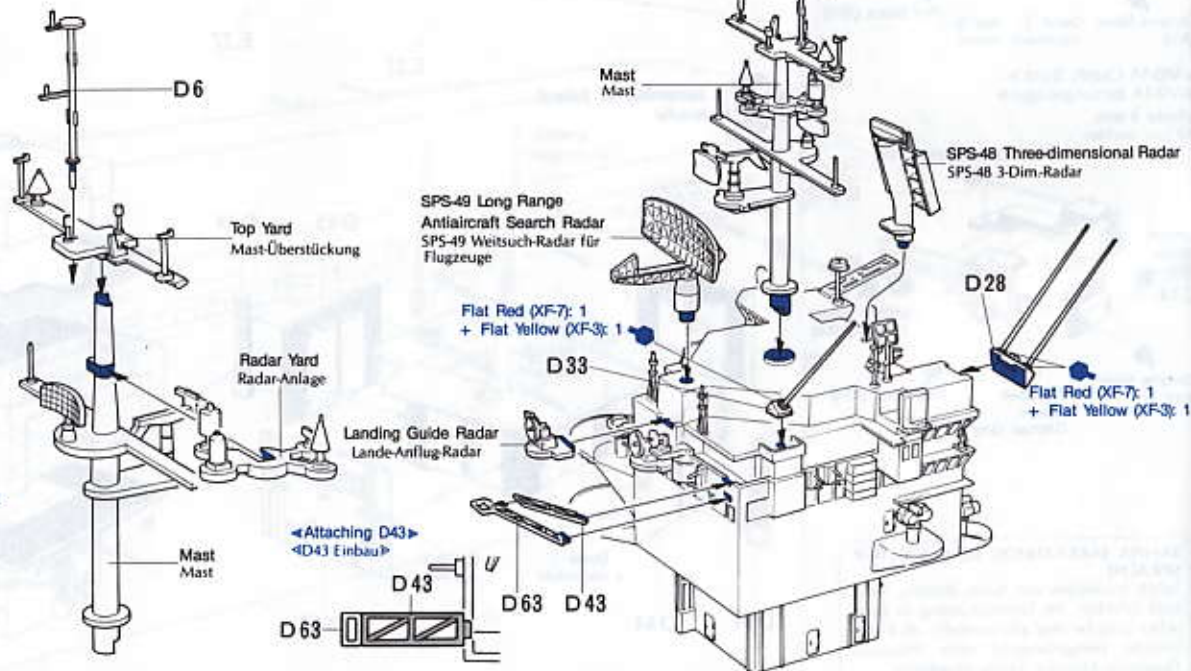
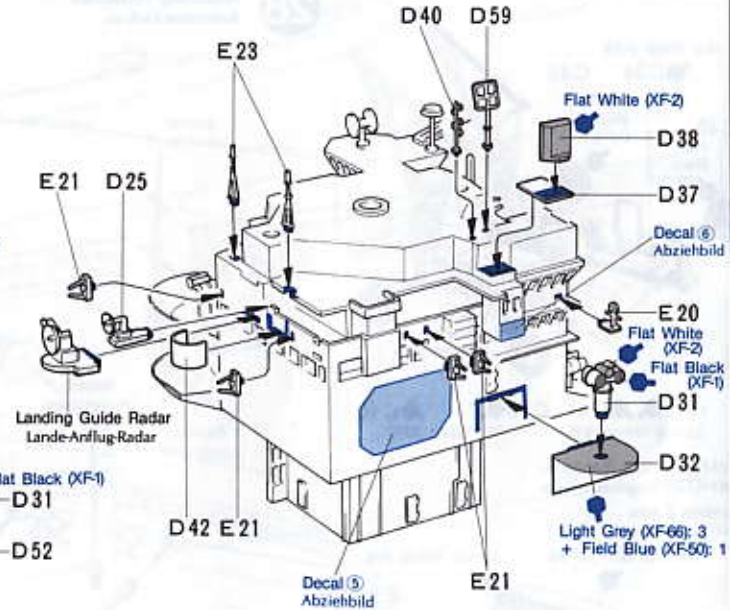
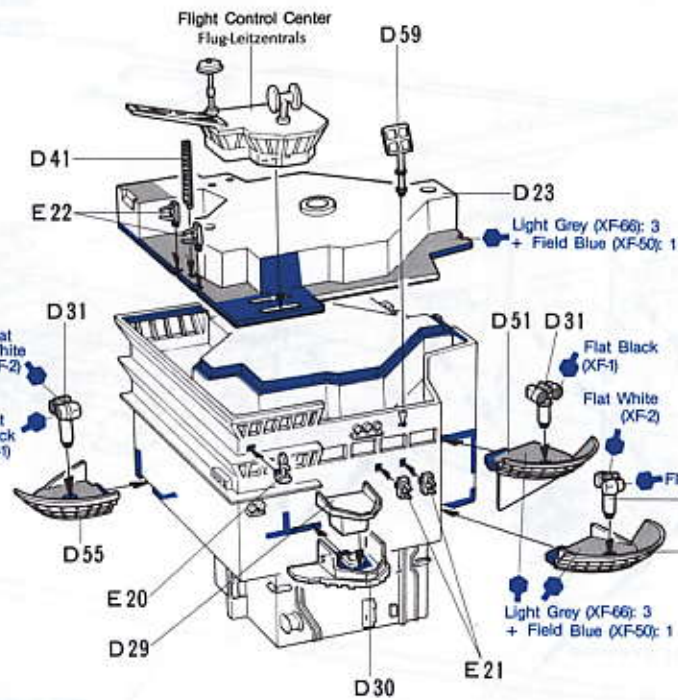
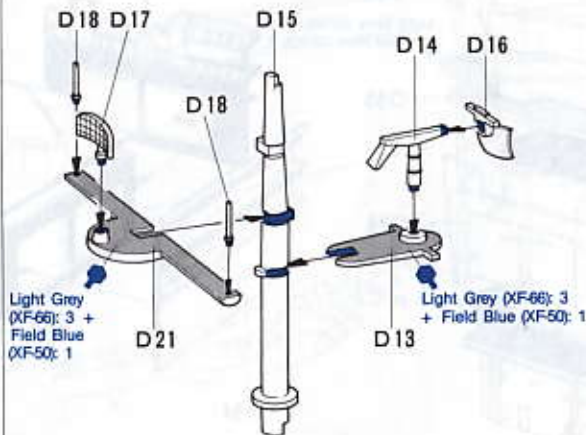

32 <<Vulcan/Phalanx Deck>>
<<Vulcan/Phalanx Deck>>

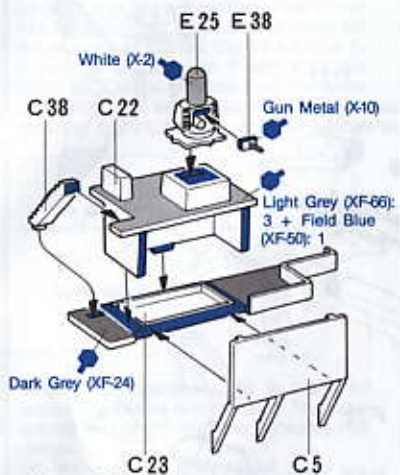

<<Antenna Wire>>
<<Antennen-Draht>>
* Refer to page 23.
* Siehe Seite 23.

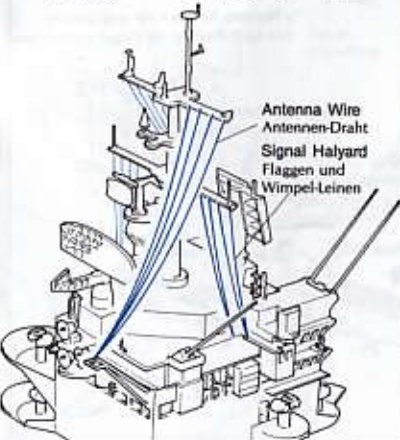

32 Attaching Island
Brücke Einbau

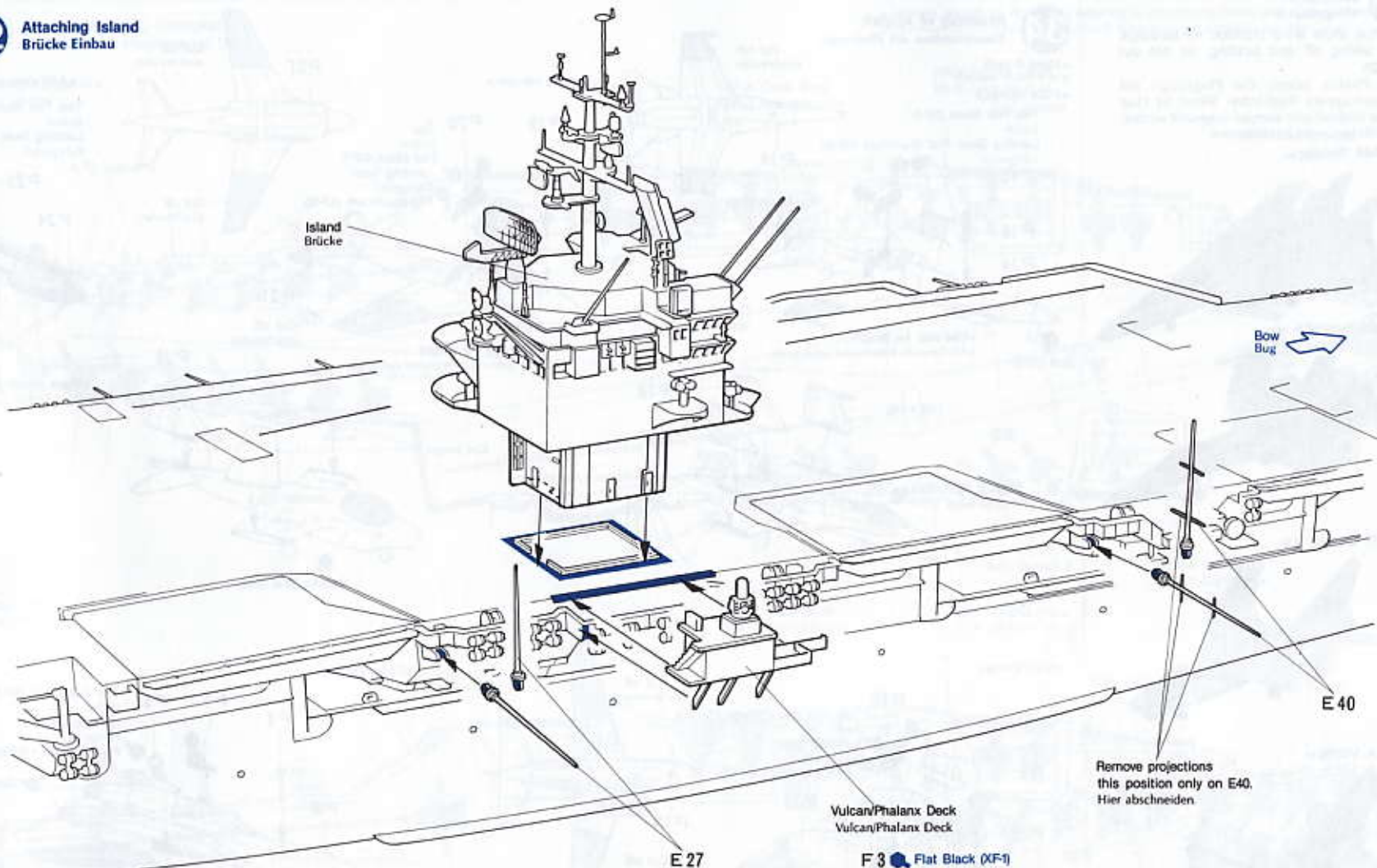

Remove projections
this position only on E40.
Hier abschneiden.

33 Assembly of Display Stand
Zusammenbau des Schiffständers

<<Name Plate>>
<<Namen-Platte>>
* Make 2 sets.
* 2 Satz machen

Paint frame and letters
in hull color or gold
leaf (X-12).
Rahmen und Buch-
staben in Rumpfarbe
oder Gold Leaf (X-12) be-
malen.

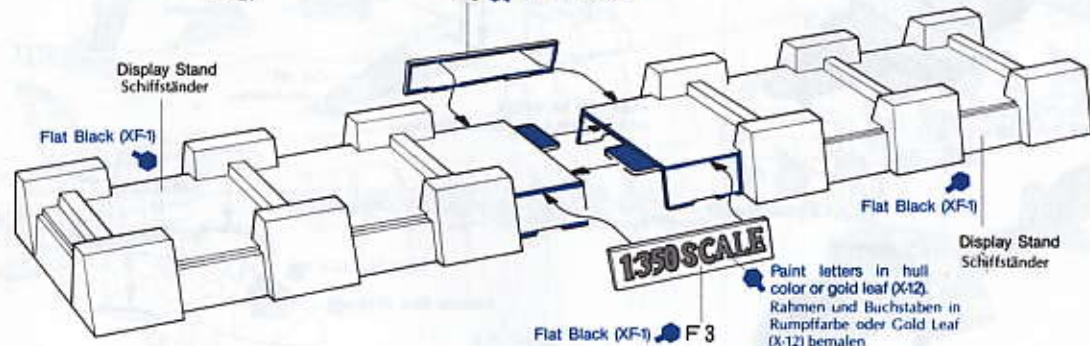
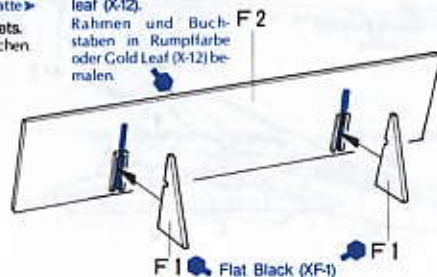

Paint letters in hull
color or gold leaf (X-12).
Rahmen und Buchstaben in
Rumpfarbe oder Gold Leaf
(X-12) bemalen

34 <Aircraft>
<Flugzeuge>

Photos show wing position for stowage. For taking off and landing, do not cut wings.

Die Photos zeigen die Flugzeuge mit hochgeklappten Tragflächen. Wenn die Flugzeuge landend oder startend dargestellt werden, Tragflächen nicht hochklappen.

<F-14A Tomcat>



<F-18A Hornet>



<A-7E Corsair II>



<S-3A Viking>



<A-6E Intruder>



34 Assembly of Aircraft
Zusammenbau der Flugzeuge

★Make 8 each
★Je 8 Stück machen.

<F-18A Hornet>

Tire: Flat Black (XF-1)
Reifen
Landing Gear: Flat Aluminum (XF-16)
Fahrgestell

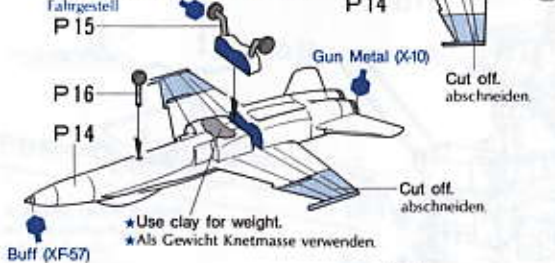

<S-3A Viking>

P10
Tire: Flat Black (XF-1)
Reifen
Landing Gear: Flat Aluminum (XF-16)
Fahrgestell

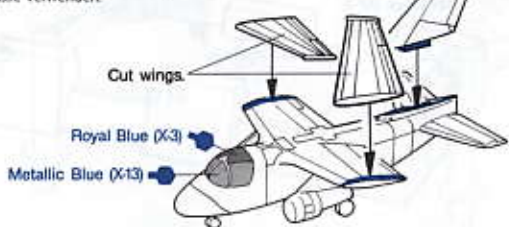
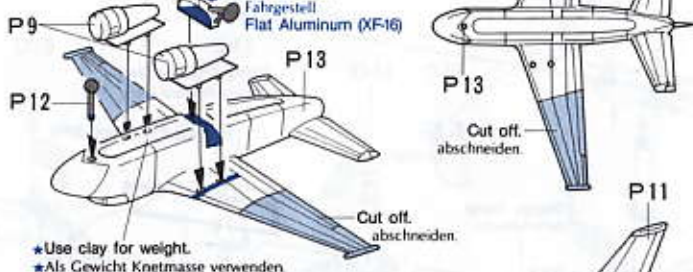

<A-6E Intruder>



<F-14A Tomcat>

P3
P7
P6
Tire: Flat Black (XF-1)
Reifen
Landing Gear: Flat Aluminum (XF-16)
Fahrgestell
Gun Metal (X-10)

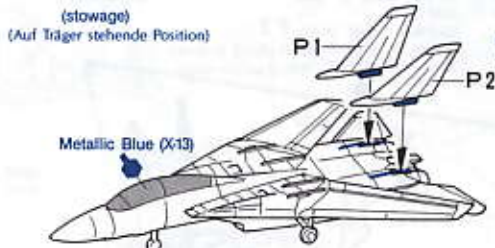

<A-7E Corsair II>

Tire: Flat Black (XF-1)
Reifen
Landing Gear: Flat Aluminum (XF-16)
Fahrgestell

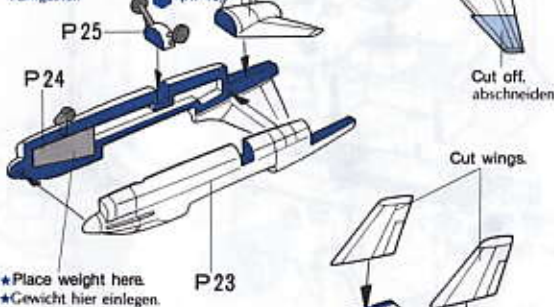

★Remove for take off and landing.
★Je nach Position die Flügel abschneiden.

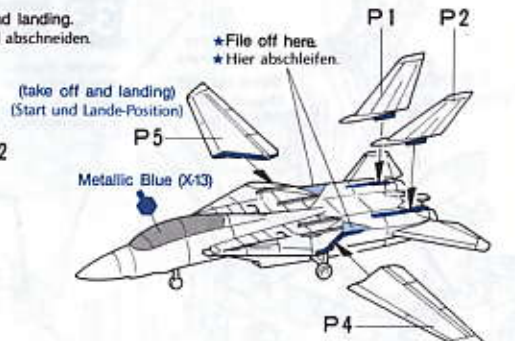
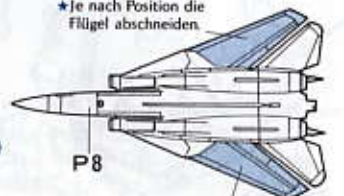

<Antenna Wire>

<Antennen-Draht>

The antenna will make your model look better. It should be added after the model has been painted. Make slender wires for the antenna as follows. Cut off a runner to a suitable length. Heat it with a candle flame for a while. Remove from the flame and pull it both ways. Attach the antenna referring to P21, box top, etc. Cut a little

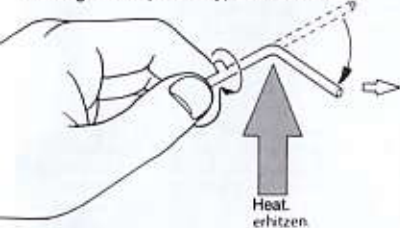

longer than necessary. Fix in place by applying adhesive with a match. The extra should be cut off after the adhesive has dried.

Mit Antenne sieht jedes Modell besser aus. Antenne nach dem Bemalen anbringen. Vom Spritzling gerade Stücke abschneiden, über Kerze drehen und dabei erhitzen. Von Kerze wegnehmen und beim drehen auseinanderziehen. Die Antenne etwas länger lassen und mit Streichholz Klebstoff anbringen. Nach trocknen des Klebers, überlängen abzwicken.

<Fixing of Flag>

<Flaggen>

Decal sheet includes naval ensign, stars and stripes and signal flags. Apply all flags to signal halyard. Apply signal decals referring P25.

Die Abziehbilder enthalten Marine-Embleme, Stars und Streifen, sowie Signal-Flaggen. Alle Flaggen und Wimpel an die Leinen. Signalbilder siehe Seite 25.

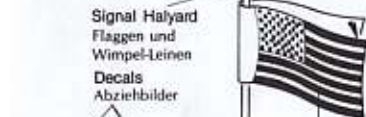

Decal
Abziehbild

Signal Halyard
Flaggen und
Wimpel-Leinen

35 Aircraft Mounting Examples Abstellung der Flugzeuge auf Deck

<During Navigation>
<Auf Fahrt>

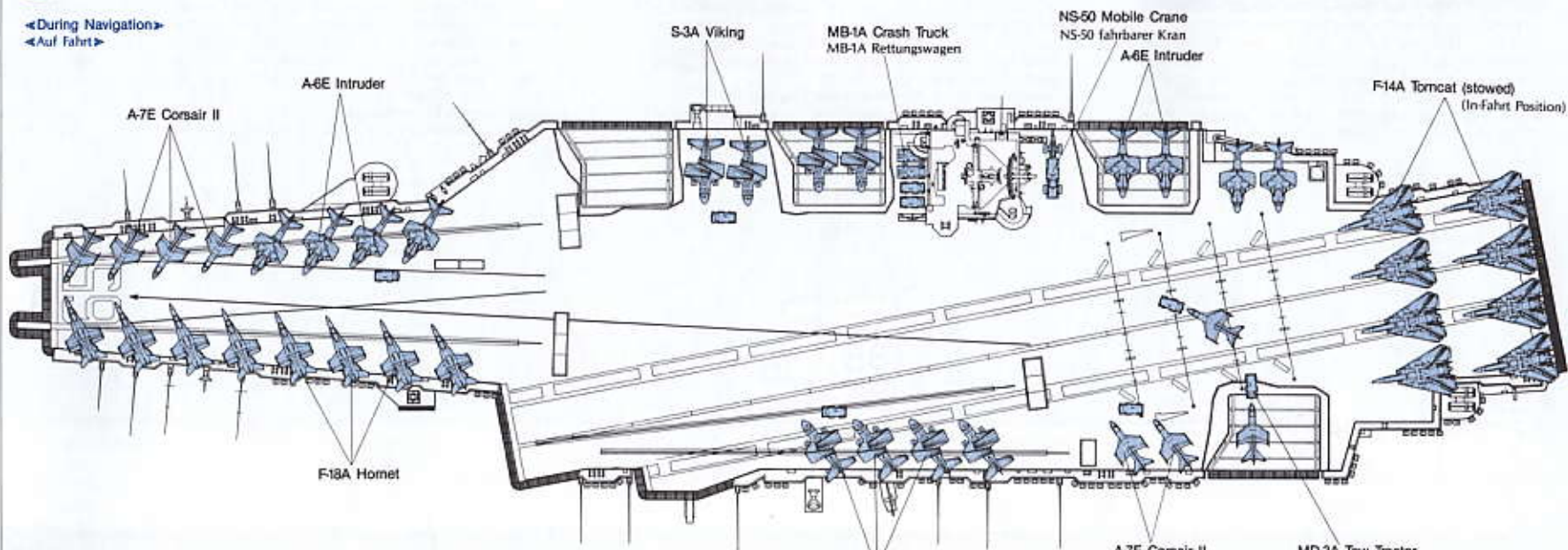

<Take Off>
<Start-Position>

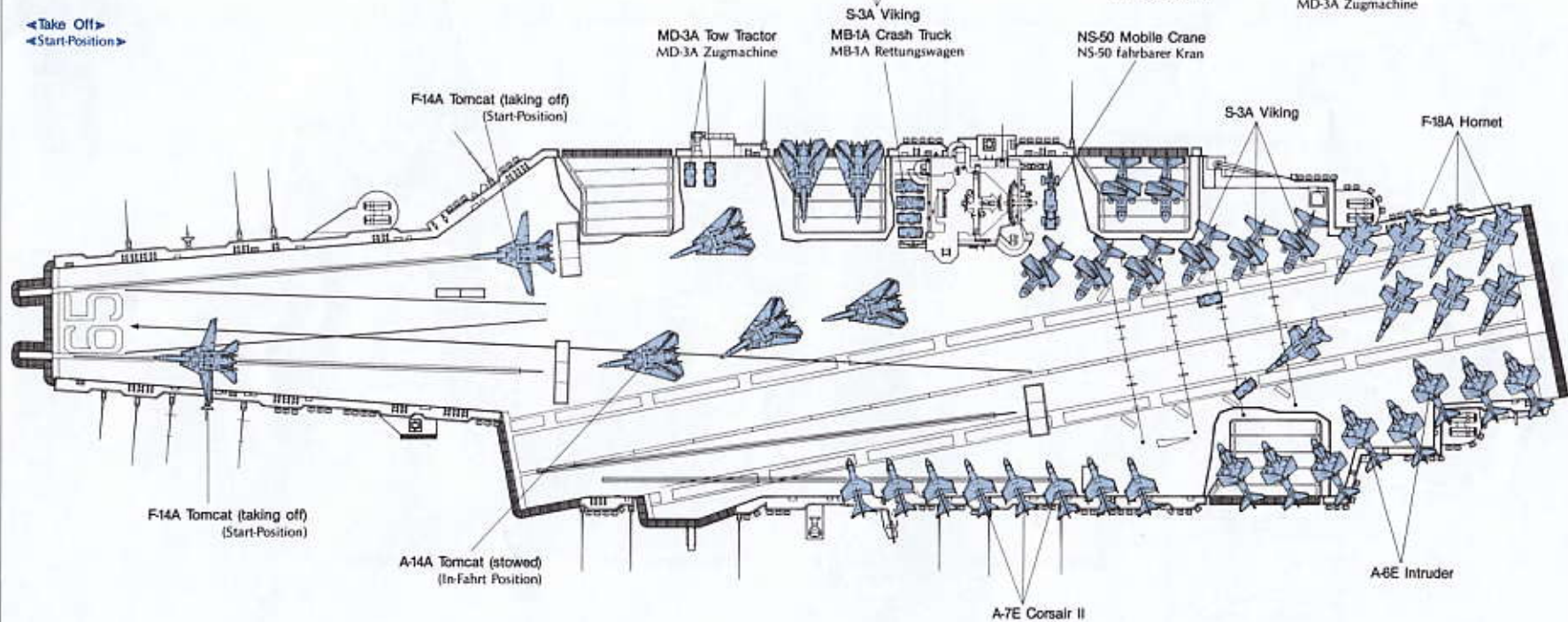

★ Arrange aircraft on flight deck referring to illustrations below and other references.
★ Wie man noch Flugzeug auf dem Deck abstellen kann, sieht man aus Bild unten.

PAINTING

<Painting of the Enterprise and Aircraft>

CVN-65 is painted overall a light grey. Hull below waterline is dark red and the water line stripe is black. The walking area of the bridge structure is a little darker grey than the hull and the flight deck is an even darker shade of grey. Tie down fittings on deck are a flat white. Other painted deck markings are in white, dashed yellow,

red/white or yellow/white center line. Refer to illustration below and the detail painting called out during construction, which should be done at that time. The U.S. Navy and Marine aircraft are painted a low visibility 3 tone grey scheme adopted in 1980. Unit insignia and aircraft numbers are painted in a small size and in one color. Refer to illustrations at right for camouflage and to page 22 for detail painting of aircraft.

< Bemalung der Enterprise und der Flugzeuge >

Die CVN-65 ist ganz in hellgrau. Der Rumpf unter der Wasserlinie ist dunkelrot, die Wasserlinie hat einen schwarzen Strei-

fen. Die begehbaren Flächen der Brückenkonstruktion sind etwas dunkelgrauer als der Rumpf und das Flugdeck einen Schatten dunkler als grau. Niedergänge am Deck sind mattweiss. Andere Deckmarkierungen sind weiss, gelb, rotweiss oder gelb-weiss. Siehe Abbildung unten und auch Bemalungsschläge in der Anleitung je nach Step. Die Flugzeuge der U.S. Navy und Marine sind in dem schlecht sichtbaren, 3-tönigen Grau der Farbvorschrift von 1980. Siehe Abbildungen rechts (Tarnbemalung) und Seite 22 (Details).

<Adding realism by painting>

The many subtle details of this model can be enhanced

by going over certain areas with a thin wash of black. This will make the details stand out much more realistically, such as the radar screens, elevator shutters, safety nets around the flight deck and the life rafts and small boats.

<Realität>

Auf dem Schiff können viele kleine Details mit etwas Geschick noch besser betont werden, zum Beispiel Radarschirme, Aufzüge, Sicherheitsnetze rund ums Flugdeck, Rettungsinseln, Schwimmwesten und kleine Boote. Man bringt einfach einen Schleier aus dünner, schwarzer Farbe an.

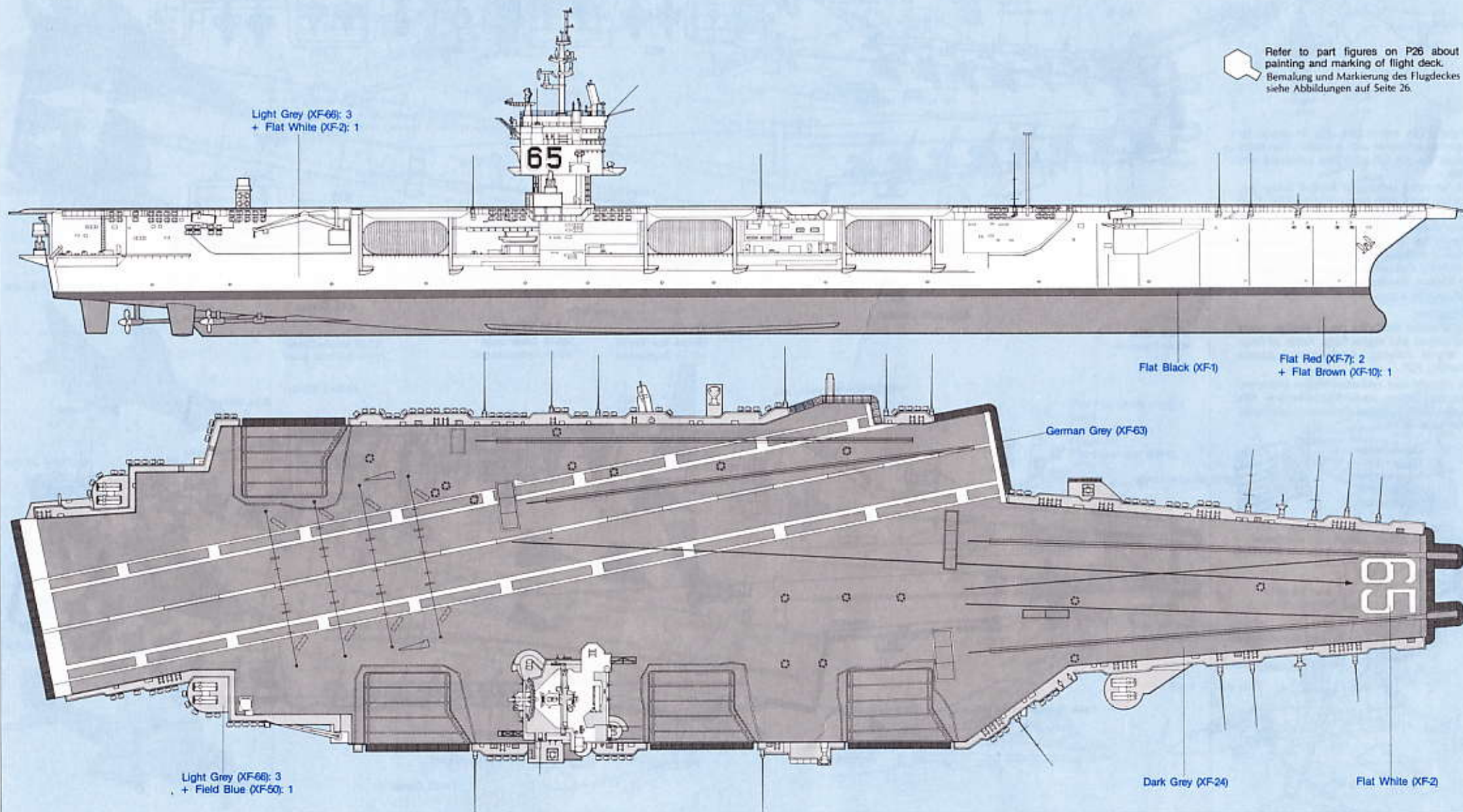

Colors Required:

Folgende Farben werden benötigt:

★From Tamiya Acrylic Paints

White	X-2
Royal Blue	X-3
Blue	X-4
Red	X-7
Lemon Yellow	X-8
Metallic Blue	X-13
Flat Black	XF-1
Flat White	XF-2
Flat Yellow	XF-3
Flat Red	XF-7
Flat Brown	XF-10
Flat Aluminum	XF-16
Medium Grey	XF-20
Dark Grey	XF-24
Field Blue	XF-50
Neutral Grey	XF-53
Buff	XF-57
German Grey	XF-63
Light Grey	XF-66

★From Tamiya Paint Markers

Chrome Silver	X-11
Gold Leaf	X-12

<About International Signal Flags>

On the decal sheet with the kit, are the international signal flags, used for communication between ships. There are 26 alphabetical flags and 10 numeral pennants. These are commonly used to relay information from one ship to another to denote position, course speed, etc. There are many flag combinations, to signal for help, casualties or ship damage etc. A triple letter signal, for example, would denote some type of medical information or request. Three flags would be used in combination for this purpose. Using the numeral pennants in combination would be to relate course, speed and other navigational information. As these international flags and pennants are utilized by all maritime countries while at sea, it is also appropriate to have them displayed on this model.

<Internationale Signal-Flaggen>

Auf den Abziehbildern im Kit sind auch die internationalen Signal-Flaggen, die der Verständigung zwischen Schiffen dienen. Es gibt 26 alphabetische und 10 numerische Wimpel. Diese werden zur Verständigung von Schiff zu Schiff verwendet um Position, Kurs, Geschwindigkeit etc. bekanntzugeben. Es gibt natürlich viele Flaggenkombinationen zum Signalisieren um Hilfe, Schäden usw.

<Decal Application>

① Remove all dust, dirt and adhesive smears with a wet cloth before applying any decals. ② The decal to be applied should be removed beforehand from the decal sheet. Cut off translucent film along colored parts. ③ Dip the decal in tepid water for about 10 seconds and then remove it onto a clean cloth. Be careful of over immersion to avoid loss of decal's adhesive. ④ Hold the backing sheet edge and slide the decal onto the model. ⑤ Wet the decal with a little water on your finger so that it can be moved more easily into position. ⑥ Press the decal down gently with a clean soft cloth to remove air bubbles and until all excess water has been fully absorbed. When a decal has to be applied to a surface which is uneven or curved, press the decal down with a hot towel so that the decal will fit the contours perfectly. Cut off the excess transparent portion around each decal. The decal must then not be touched until dry.

<Single-Letter Signals>



B

I am taking in, or discharging, or carrying dangerous goods.

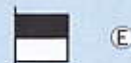

E

I am altering my course to starboard.



H

I have a pilot on board.



M

My vessel is stopped and making no way through the water.



U

You are running into danger.



X

Stop carrying out your intentions and watch for my signals.

<Double-Letter Signals>



S

I am under way.

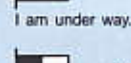

U

I am carrying out exercises. Please keep clear of me.



Y

I am carrying out exercises. Please keep clear of me.



F

I am in charge of co-ordinating search.

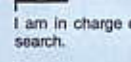

R

I am in charge of co-ordinating search.

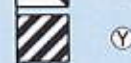

O

Port is mined.

Port is mined.

<Using Example of Numeral Pennants>

Generally pennant is used with double-letter signals.

Reference: International Code of Signals



R



U

I am carrying out maneuvering trials.

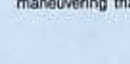

I



N



E

You should proceed with great caution; hostile submarine sighted.

★Signal flags are shown with red decal numbers and alphabet in decal sheet.

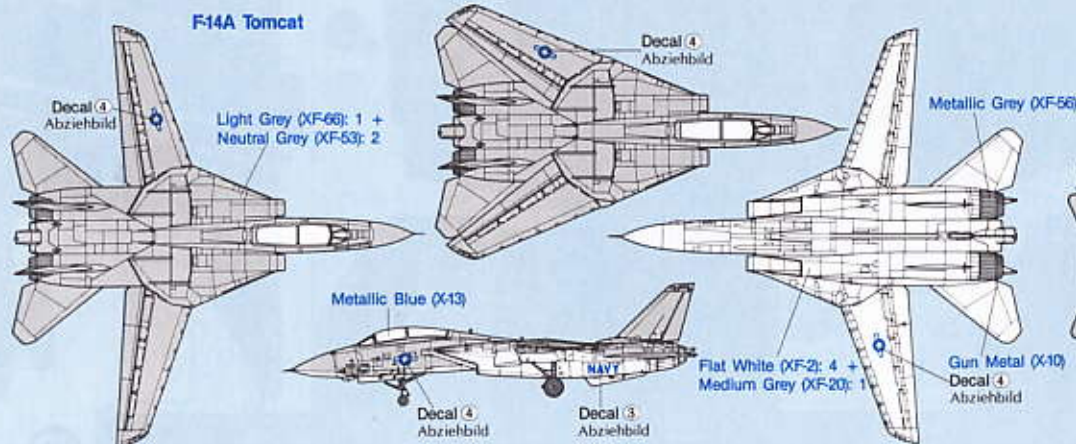

F-14A Tomcat



F-18A Hornet

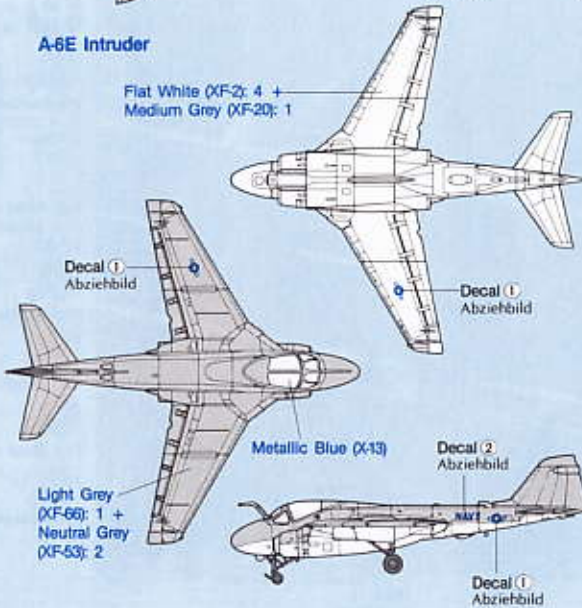

A-6E Intruder

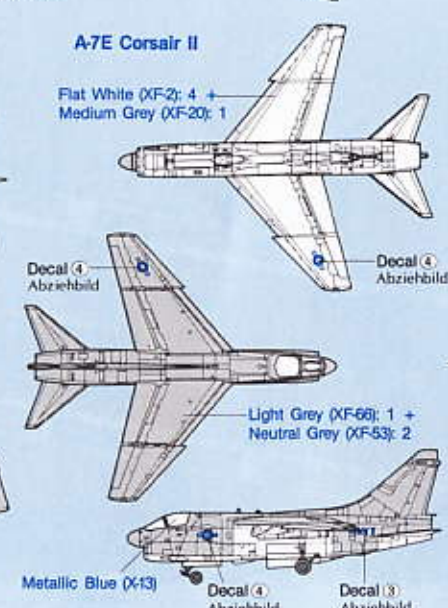

A-7E Corsair II

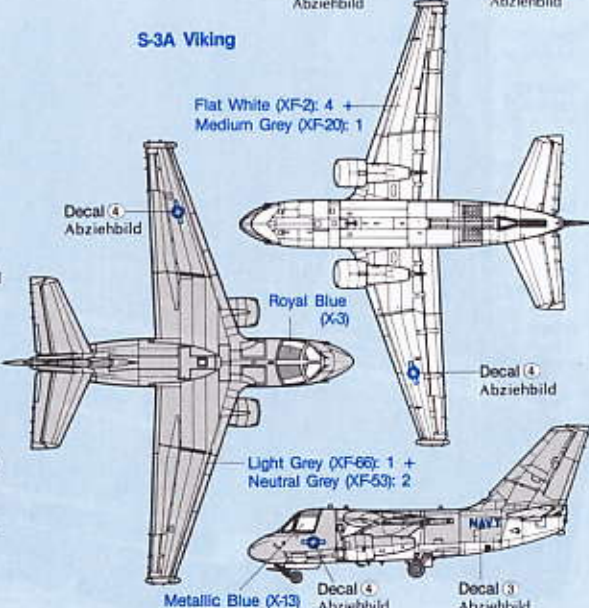

S-3A Viking

PARTS

Painting Color of Flight Deck



Fore Flight Deck

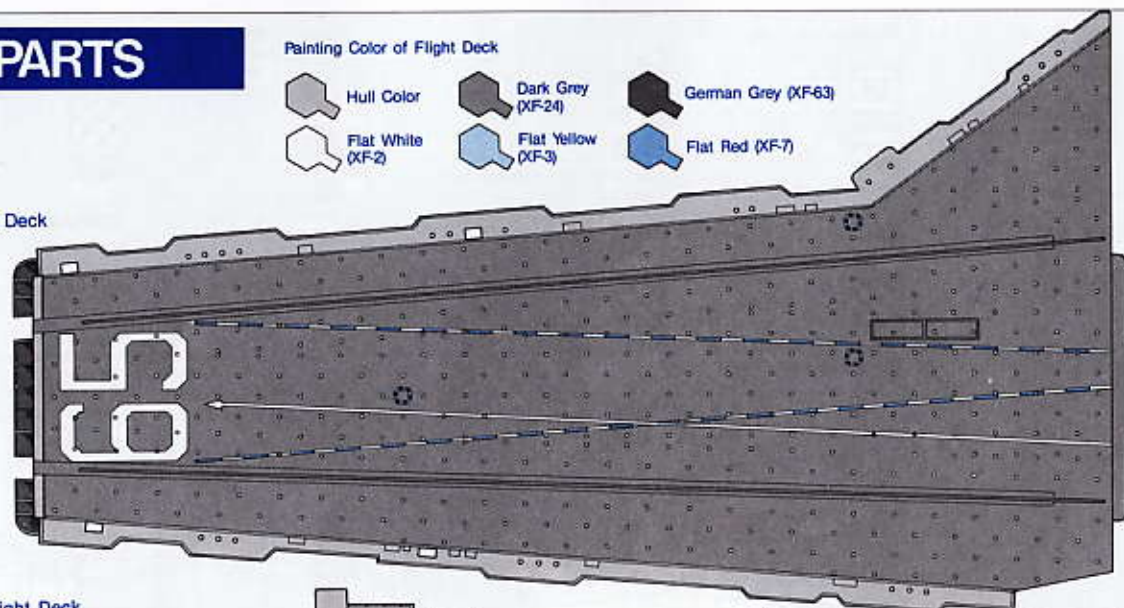

Aft Flight Deck

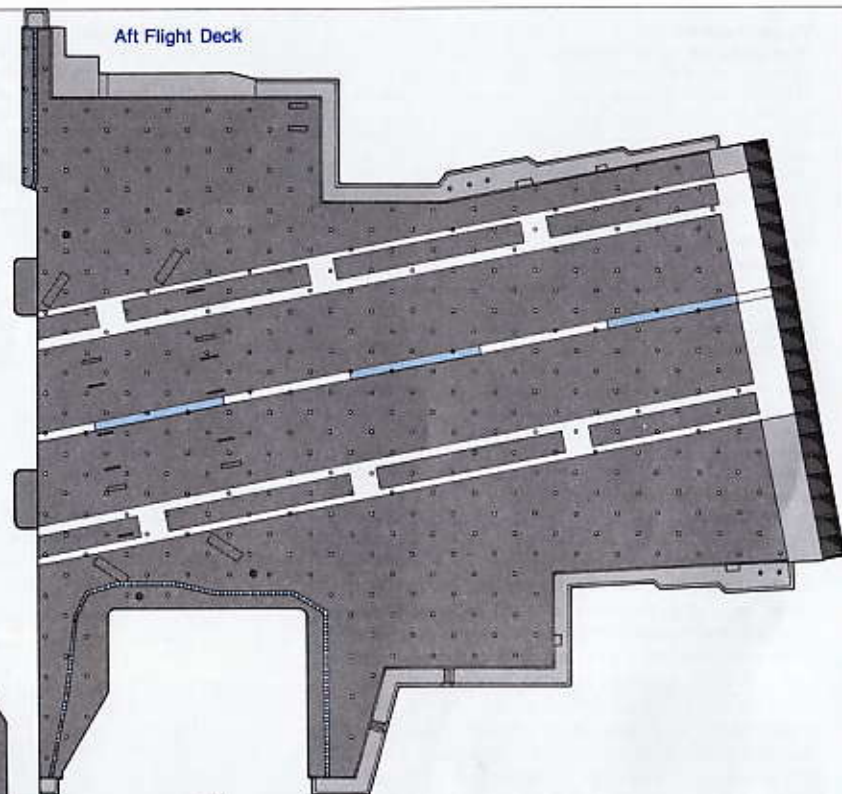

Midship Flight Deck

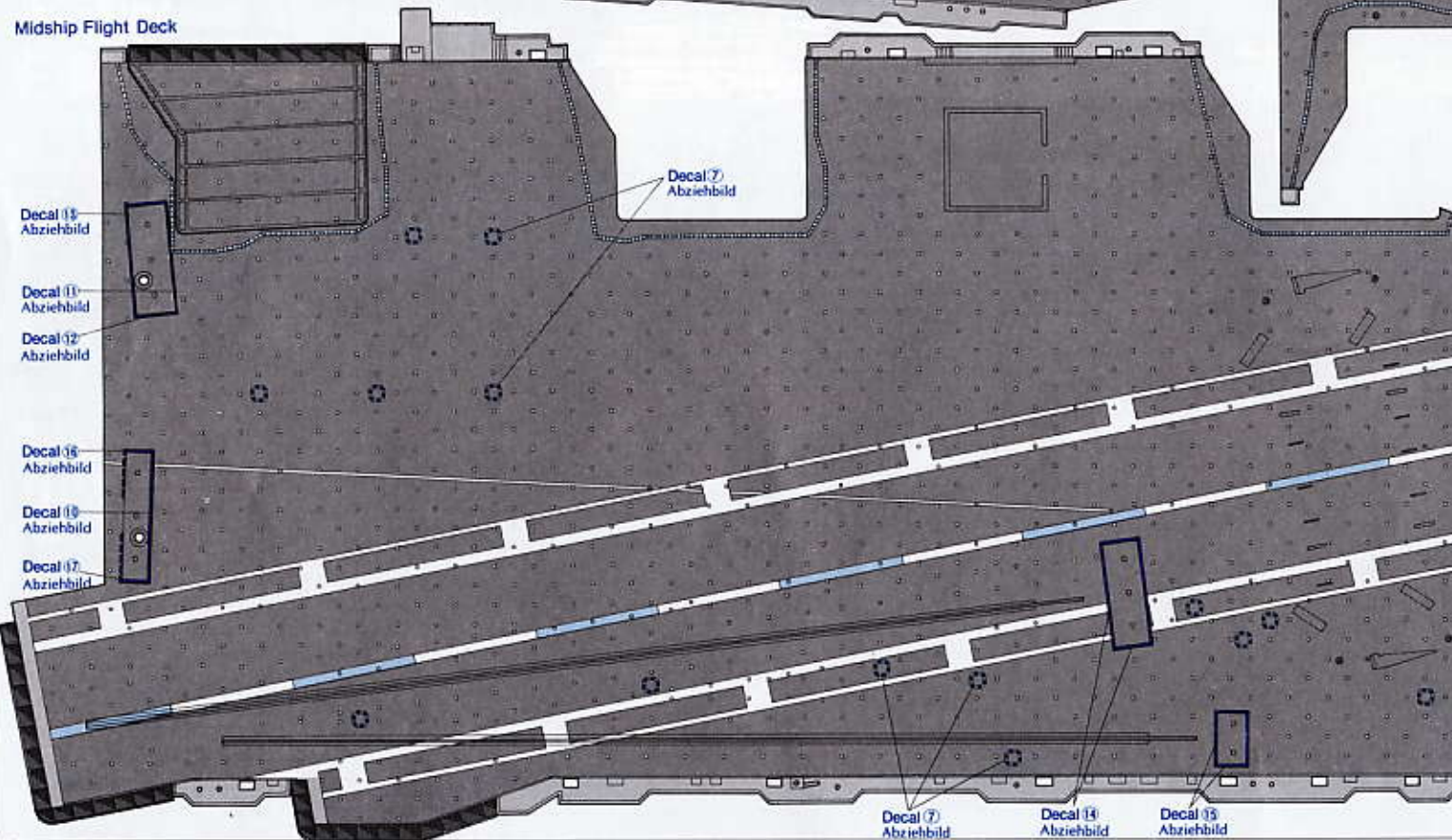

P PARTS (8 pcs.)

Neutral Grey (XF-56):
2 + Light Grey
(XF-66): 1

Flat White (XF-2):
4 + Medium Grey
(XF-20): 1

Metallic Blue (X-13)

Gun Metal (X-10)

Flat Black (XF-1)

Flat Aluminum
(XF-16)

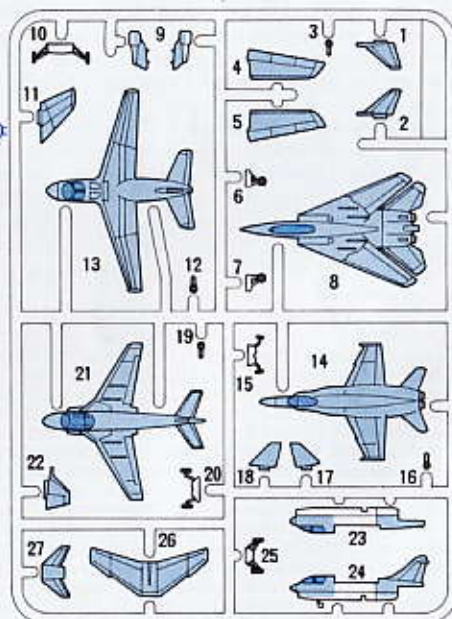

PARTS

A PARTS

-  Hull Color
-  German Grey (XF-63)
-  Light Grey (XF-66): 3 + Field Blue (XF-50): 1
-  Dark Grey (XF-24)

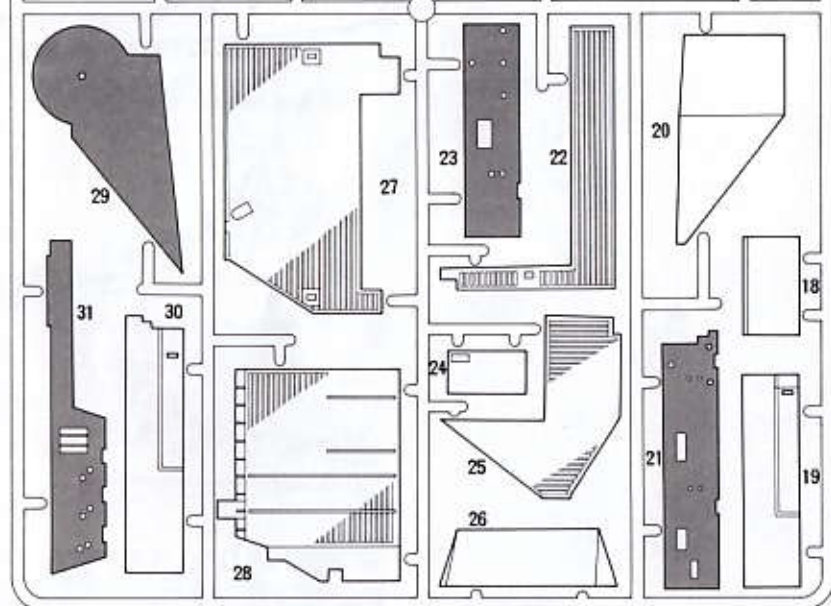
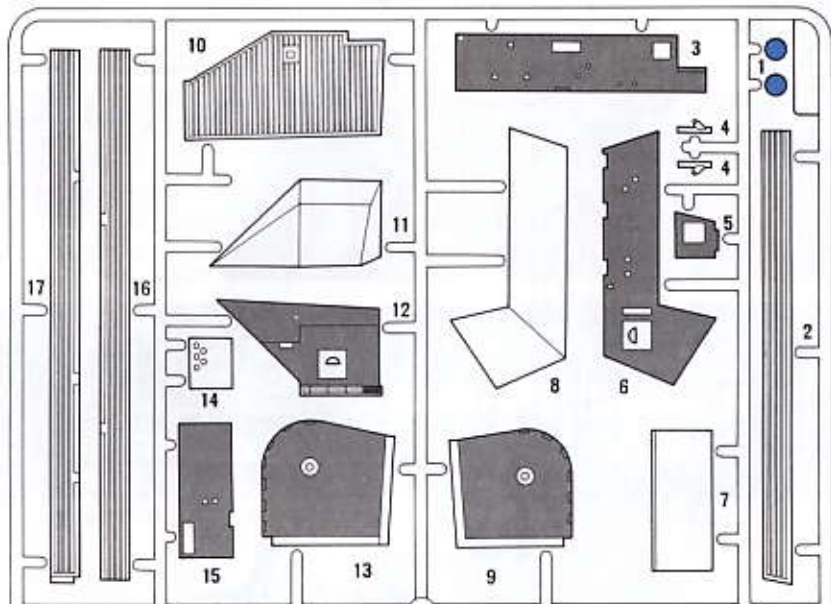

C PARTS

-  Hull Color
-  Light Grey (XF-66): 3 + Field Blue (XF-50): 1
-  Dark Grey (XF-24)
-  German Grey (XF-63)
-  Lemon Yellow (X-8)
-  Flat Black (XF-1)
-  Flat White (XF-2)

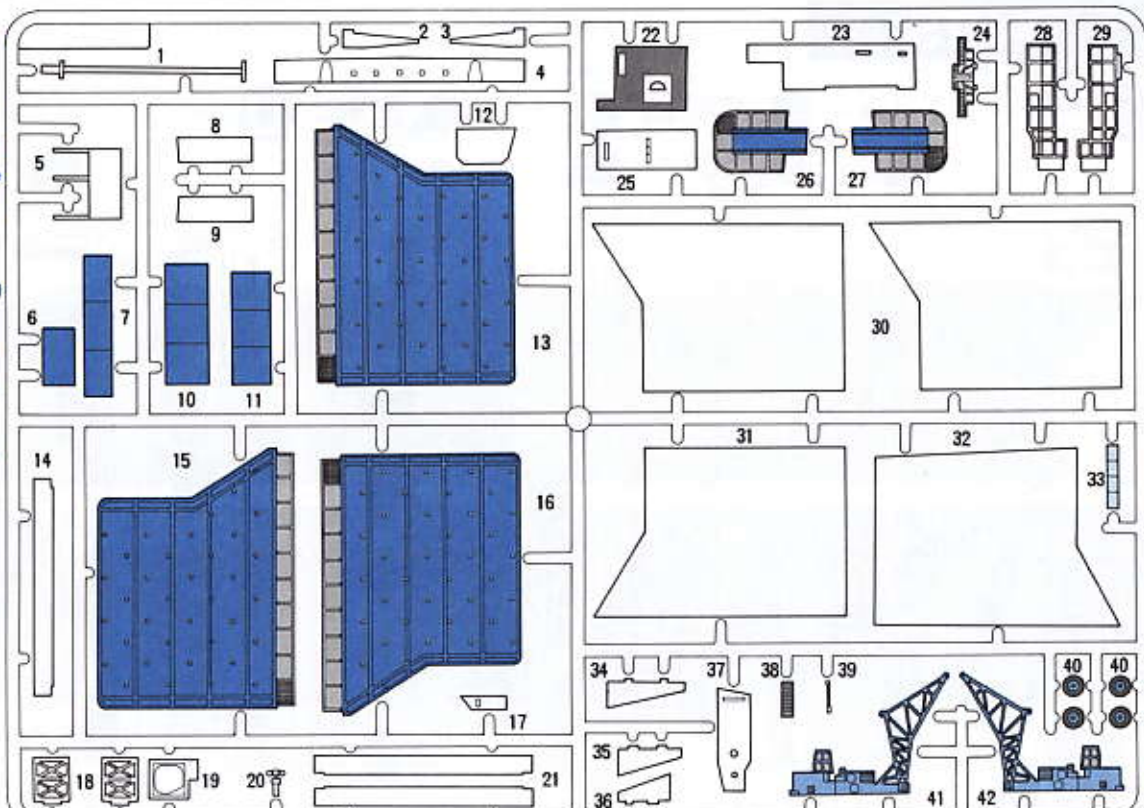

E PARTS (2 pcs.)

-  Hull Color
-  Lemon Yellow (X-8)
-  Flat Black (XF-1)
-  Flat White (XF-2)
-  Dark Grey (XF-24)
-  Gun Metal (X-10)

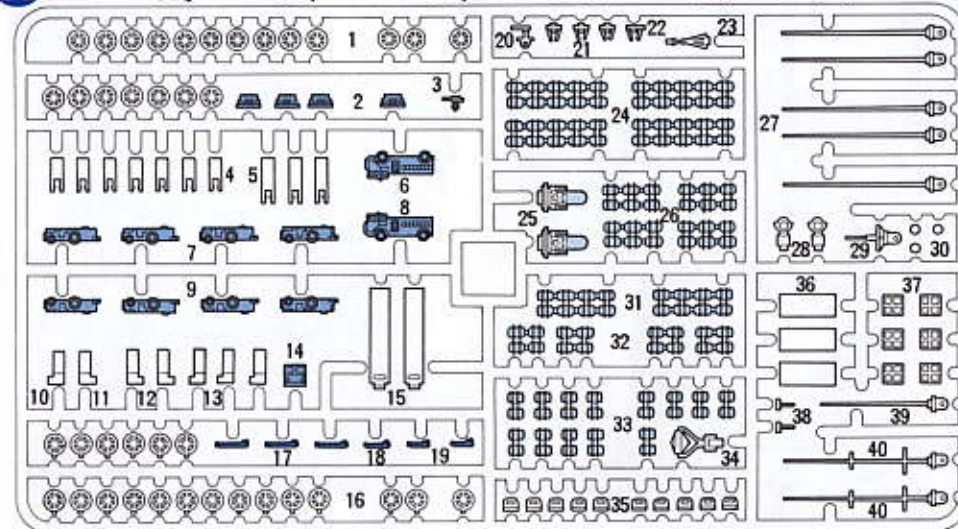

F PARTS (2 pcs.)

-  Gold Leaf (X-12) or Hull Color



PARTS

B

PARTS

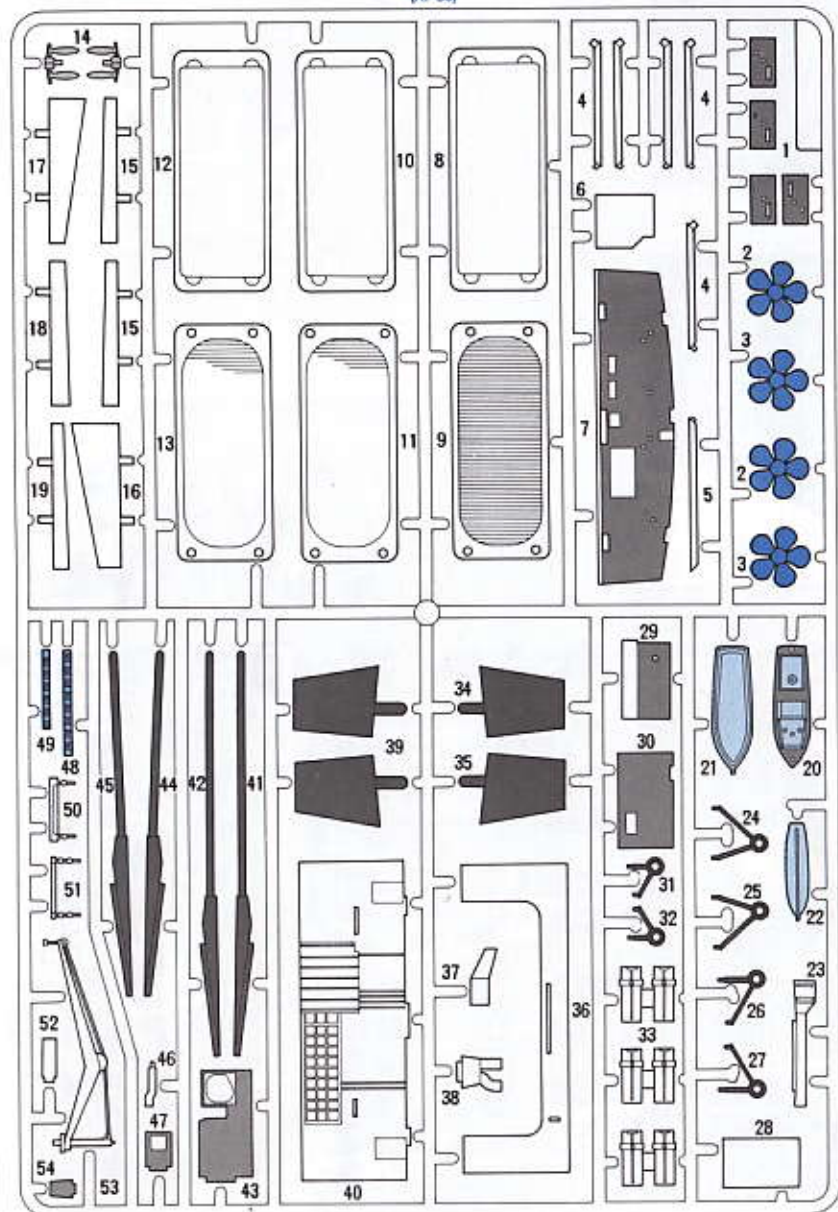

D

PARTS

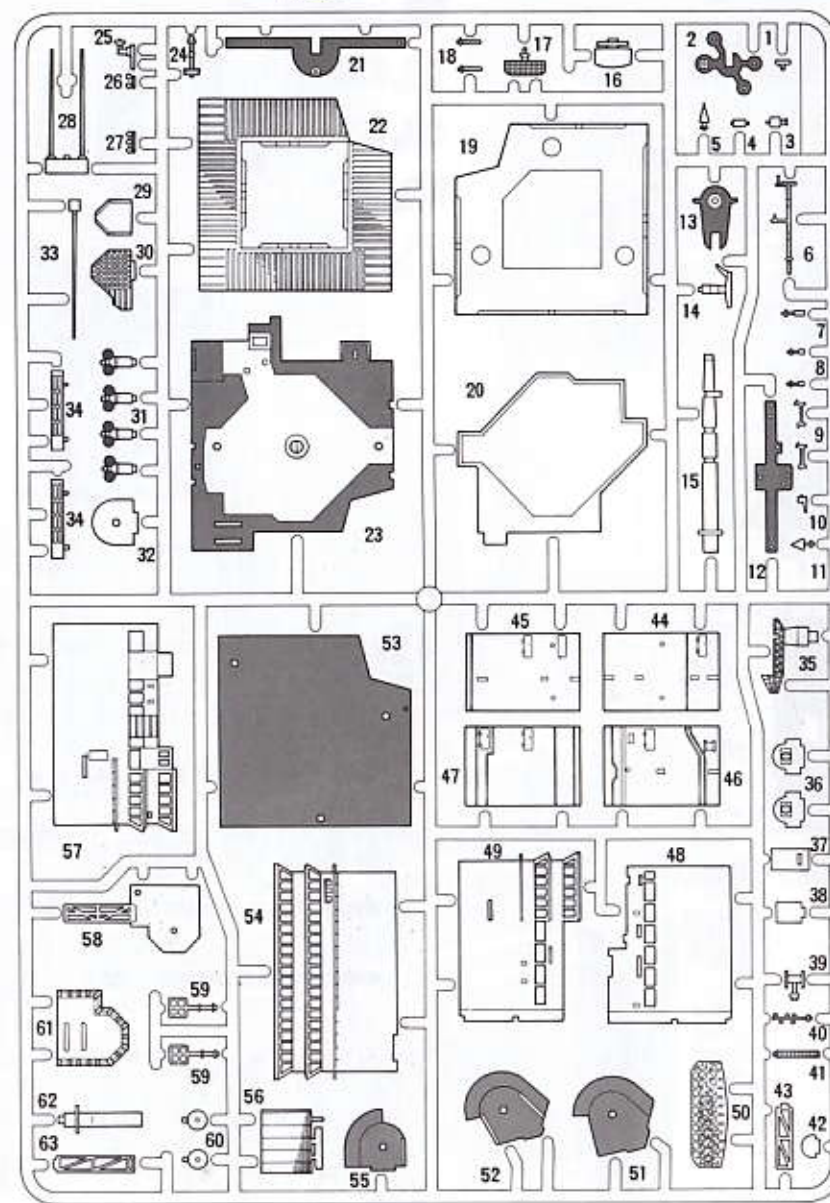
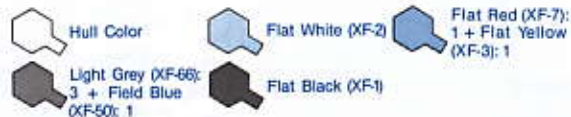

Hull (with hull frame B)	X1
Bow	X1
Display Stand	X2
Decal (for carrier)	X1
Decal (for aircraft)	X1
<Metal Parts Bag>	
Hull Frame A	X1
Hull Frame C	X1
Tweezers	X1
Nylon Line	1.5 m



BUILD A COLLECTION OF TAMIYA PRECISION SHIP MODELS

1/350 GERMAN BATTLESHIP SHIP BISMARCK



1/350 JAPANESE BATTLESHIP YAMATO



1/350 U.S. NAVY BATTLESHIP BB-62 NEW JERSEY



1/350 JAPANESE BATTLESHIP MUSASHI

